

**INSTRUCTION  
BOOK**

*for the*

**1½ LITRE JAGUAR**



**1946/47/48**

---

# INSTRUCTION BOOK

FOR THE



## JAGUAR

---

1 <sup>1</sup>/<sub>2</sub> LITRE MODEL

---

1946-7-8

PRICE 5/-

**JAGUAR CARS LIMITED**  
COVENTRY, ENG.

Directors:

Sir W. Lyons, Chairman and Managing Director

A. Whittaker, General Manager

W. M. Heynes, M.I.Mech.E. (A.D.), M.S.A.E.

E. F. Muckvale, F.C.C.S., Secretary

Telephone:  
COVENTRY 42677 (P.B.X.)  
Code: Bentley's 2nd

Telegraphic Address:  
"JAGUAR," COVENTRY  
Telex 31,622

---

## PREFACE

THIS book of instructions has been compiled to give assistance to the owners of the Jaguar in the care and maintenance of their car, and all matter included is relative to the 1½ Litre Jaguar 1946-7-8 Model.

Every effort has been made in design to render the few adjustments easy and accessible.

The continued good running of a car depends essentially upon the care and attention it receives from the owner, and we earnestly recommend that careful attention be paid to the following instructions, particularly to those which deal with general upkeep and lubrication. All the necessary maintenance instructions for body, engine and chassis, are combined in the Mileage and Maintenance Diary incorporated in this book.

It is unlikely that the owner will desire to carry out major repairs, but an intimate knowledge of the details and assembly will give at least a greater interest in the car's running and increased confidence in the rare event of a mishap. This book is fully illustrated and, by the aid of the descriptions given, it should be easy for those of a mechanical mind to obtain a working knowledge of the car.

A section will be found at the end of the book which will enable the owner to trace any fault and correct it. Should any further information be required, our Service Department will be pleased to give all possible assistance.

The car will run for many thousands of miles before a general overhaul becomes desirable, and the work then entailed should be carried out by a skilled mechanic. We have not, therefore, given detailed instructions for dismantling the units, but the mechanical parts are illustrated in detail for the benefit of the mechanic who will have the work to do. It is desirable that any overhaul or repair work should be carried out at the works or by one of our Dealers, who, being familiar with the construction of the car, are suitably equipped to give after sales service.

## CONTENTS

	PAGE
Preface .. .. .	ii
Contents .. .. .	1 and 2
Index to Illustrations .. .. .	3
Memos. and Licence Data .. .. .	4
General Data .. .. .	5
Road Speed Data .. .. .	6 and 7
Driving Hints .. .. .	8 and 9
A Few "Don'ts" .. .. .	10
<b>General Upkeep</b> .. .. .	<b>11 and 12</b>
Regular Inspection .. .. .	11
Cooling System .. .. .	11
Ammeter Readings .. .. .	11
New Engines .. .. .	12
Automatic Thermostat .. .. .	12
<b>Lubrication</b> .. .. .	<b>12 to 15</b>
Engine .. .. .	12
Tecalemit Oil Cleaner .. .. .	13
First 750 Miles .. .. .	13
Ignition Distribution .. .. .	13
Dynamo and Starter .. .. .	14
Gear Box .. .. .	14
Water Pump .. .. .	14
Rear Axle Lubricant .. .. .	14
Propeller Shaft Universal Joints .. .. .	14
Front Axle .. .. .	14
Steering .. .. .	14
Controls, etc. .. .. .	14
Oil Guns .. .. .	14
Recommended Lubricants .. .. .	15
Upper Cylinder Lubrication .. .. .	15
<b>Care of the Tyres</b> .. .. .	<b>16 and 17</b>
Fitting and Removal Instructions .. .. .	16
Correct Tyre Pressures .. .. .	17
<b>Brakes</b> .. .. .	<b>18 to 21</b>
The Brake Shots .. .. .	18
<b>Carburettor</b> .. .. .	<b>22 to 25</b>
Causes of Bad Running .. .. .	24 and 25

CONTENTS—continued.

	PAGE
Petrol Pump .. .. .	26
<b>Electrical System</b> .. .. .	28 to 32
Dynamo and Combined Cut-Out and Regulator Unit .. .. .	28
Electric Starter .. .. .	28
Ignition .. .. .	28
Fuses .. .. .	29
Battery .. .. .	29
Head Lamps .. .. .	29
Lucas Horns .. .. .	30
"Trafficators" .. .. .	30
Petrol Gauge .. .. .	30
How to Obtain the Best Service from the Electrical System .. .. .	31
Diagram .. .. .	32
<b>Engine</b> .. .. .	33 to 39
Sparking Plugs .. .. .	33
Distributor Contact Breaker .. .. .	33
Valve Clearances .. .. .	33
Decarbonising .. .. .	34
"Pinking" .. .. .	34
Grinding the Valves .. .. .	36
Tappet Push Rods .. .. .	37
Crankshaft .. .. .	38
Valve Timing .. .. .	39
Ignition Timing .. .. .	39
Gearbox .. .. .	40
Front Axle .. .. .	40
Steering .. .. .	41 to 43
Chassis Suspension .. .. .	43 and 44
Rear Axle .. .. .	44
Propeller Shaft .. .. .	44
Clutch .. .. .	46
<b>Possible Troubles and their Remedies</b> .. .. .	47
<b>Location and Correction of Faults</b> .. .. .	48 and 49
<b>Coachwork</b> .. .. .	50 to 54
<b>Mileage and Maintenance</b> .. .. .	55 to 59
<b>Conversion Tables</b> .. .. .	60 and 61
<b>Road Distances</b> .. .. .	62
<b>Service</b> .. .. .	63
<b>Accessories and Equipment</b> .. .. .	64

INDEX TO ILLUSTRATIONS

	PAGE
Controls .. .. .	8
Gearbox .. .. .	13
Tyres .. .. .	17
Brakes .. .. .	18, 19
Brakes Linkage .. .. .	18
Brake Arrangement .. .. .	Folder Facing page 20
Brake Layout .. .. .	21
Carburetter .. .. .	23
Petrol Pump .. .. .	27
Cut-out, Regulator and Fuse Box .. .. .	29
"Trafficators" .. .. .	30
Electrical Wiring .. .. .	32
Engine (Cylinder Head) .. .. .	33
Power Unit .. .. .	34 and 35
Tappet Adjustment .. .. .	37
View inside Crankcase .. .. .	38
Timing Diagram .. .. .	39
Synchro-mesh Cones .. .. .	40
Front Axle Setting Diagram .. .. .	41
Steering Gear .. .. .	43
Rear Axle Details .. .. .	45
Clutch .. .. .	46
Lowering Head of Drop-head Coupe .. .. .	51, 52
Door Hinges .. .. .	53
Spare Wheel Housing .. .. .	54

05/9  
54/9

## MEMOS. AND LICENCE DATA

## Personal Memos.

Owner's Name .....

Address .....

Telegraphic Address .....

Telephone Number .....

Notes .....

## Car Memos.

Date of Car Purchase .....

Insurance Policy .....

R.A.C. or A.A. Number .....

## Licence Data.

Registration Number .....

Car Licence Date .....

Driver's Licence Number .....

Chassis No. .... Given under bonnet at o/s of Engine.

Engine Number .... Stamped on o/s of Cylinder Block.

Number of Cylinders	.. .. .	4
Diameter of Cylinders	.. .. .	73 m/m.
Stroke of Piston	.. .. .	106 m/m.
Capacity of Engine	.. .. .	1775.8 c.c.
R.A.C. Rating	.. .. .	13.23

## GENERAL DATA

Number of Cylinders	.. .. .	4
Bore of Cylinders, m/m	.. .. .	73
Stroke of Crank, m/m	.. .. .	106
Cubic Capacity, c.c.	.. .. .	1775.8
Compression Ratio	.. .. .	7.5
Firing order	.. .. .	1.3.4.2
Brake Horse Power at 1,000 r.p.m.	.. .. .	16.7
	2,000 .. .. .	36.7
	3,000 .. .. .	55
	4,000 .. .. .	62
Peak	4,600 .. .. .	65

## Oil Capacity.

Engine	.. .. .	12 pints
Gearbox	.. .. .	2 ..
Rear Axle	.. .. .	2 ..

Water Capacity of Radiator and Engine .. 2½ gallons

Petrol Capacity .. .. . 14 gallons

Wheelbase	.. .. .	9' 4½"
Track, Front	.. .. .	4' 4"
Track, Rear	.. .. .	4' 7"
Turning Circle (between curbs)	.. .. .	38' 0"
Tyre Size	.. .. .	5.25 x 18

## Overall Dimensions.

Length	.. .. .	15' 0½"
Width	.. .. .	5' 6"
Height	.. .. .	5' 0"

## Car Weight (Ready for the Road).

(LESS PETROL)

1½ Litre Saloon	.. .. .	26	Qrs.
-----------------	---------	----	------



## DRIVING HINTS

**Controls.** Before attempting to start the engine, a new owner should examine the illustration showing the controls.

The trafficator, horn and screen wipers are also interconnected to the ignition switch, and will therefore only operate after the ignition is switched on.

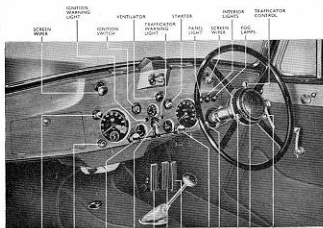

Instrument Panel of 1 1/2 Litre Special Equipment Model

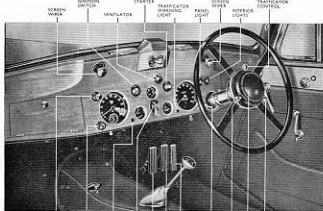

Instrument Panel of 1 1/2 Litre Standard Model

## DRIVING HINTS

**To Start the Engine.** Place the gear lever in the neutral position and see that the handbrake is on, pull the jet control knob, switch on the ignition, slightly depress accelerator pedal, and operate starter. As soon as the engine fires, release the starter button, then push the jet control half way, and as the engine warms up, push the control back to its normal position.

It is important that the jet control should not be used more than is necessary, the prolonged use of a rich mixture causes rapid cylinder wear.

**"Warming Up"** In cold weather the engine should be allowed to run, not too slowly, for a few minutes to warm up the oil, and on no account should the engine be raced up from dead cold at any time. It is a decided advantage to warm up the engine as quickly as possible in cold weather, as this minimises cylinder wear. A thermostat is fitted which greatly reduces the warming-up period. A good warming-up speed is about 1,000-1,200 r.p.m.

In winter the oil in the engine and gearbox becomes thick when the car has been standing for some hours, this causes the engine to be stiff and to require an unusual effort to turn it. It is important, therefore, particularly in cold weather, that the correct grade of oil is used.

The oil pressure should read not less than 20 lbs. per square inch when the car is travelling at normal speeds and the oil is hot, but when the engine is cold much higher pressures will be recorded.

A habit should be made of occasionally reading the oil pressure gauge and ammeter during the course of a run, to see that the oil pump and dynamo are functioning correctly.

To avoid excessive clutch wear, always start on the level in either first or second gear. For starting on a steep hill, it is advisable to use first gear.

To start in third or high gear means an undue amount of slip on the clutch.

When held up in a traffic jam, do not hold the clutch out longer than necessary, if there appears to be a long wait, it is always advisable to slip the gear into neutral and re-engage when moving off.

When driving under normal conditions, never use the clutch pedal as a foot rest, as this will hold the carbon ring in contact with the clutch and cause undue wear on the bearing and, possibly, failure of the clutch.

**Gear Changing.** The synchro-mesh gearbox provides a synchronised easy gear change for all conditions excepting changing down into First gear with the car in motion. This particular gear change is seldom required, and changes into First or Reverse are mostly made when the car is at rest. Thus 95 per cent. of the gear changes are made easily with the synchro-mesh gearbox.

When changing into a synchronised gear the movement should be slow and deliberate. **Do Not Hurry.**

Upon its first movement the change speed lever will encounter a slight resistance from the synchronising cones. The continuance of a steady pressure will synchronise the gears and the resistance will be overcome as the driving dogs slide silently into engagement.

**The change speed lever must always be pushed right home to secure full engagement.**

**Using the Brakes.** Specially designed Girling brakes operating on all four road wheels need only a very light pedal pressure to bring the car to rest. The brakes may be safely applied at any road speed. The controls are arranged to give complete compensation and balance between each of the four brakes.

After the car has been washed with a high pressure hose, always test the brakes when starting out, in case water has entered the drums and saturated the linings. If this has occurred, make one or two fairly hard brake applications at twenty to thirty miles an hour to clear the water off the drums to avoid the possibility of being caught in an emergency when travelling fast with ineffective brakes.

**High Curbs.** We would advise the owner to be wary of drawing up too close to high curbs and to acquire the habit of leaving about a foot clearance between the road wheels and the curb, thus avoiding possible damage to the low sweeping front wings.

## A FEW "DON'TS"

- DON'T** neglect to change the engine oil and clean the sump, after the first 750 miles ; always use a good lubricant as recommended.
- DON'T** drive off on full throttle immediately after starting from cold. Drive moderately for the first mile or so to give the oil a chance to warm up.
- DON'T** make a practice of keeping the engine oil to the bottom level on the dipstick, but do not overflow the sump. It is dangerous to run with too little oil, and wasteful to run with too much. Keep the oil level just below the top mark on the dipstick.
- DON'T** continue to run the engine if the oil pressure gauge indicates an abnormally low pressure, but examine the engine to find the cause.
- DON'T** allow the engine to exceed 2,500 r.p.m. during the first 500 miles. The equivalent road speeds are as follows:—

Maximum Speeds for first 500 miles		
		m.p.h.
First Gear	.. ..	11
Second Gear	.. ..	18
Third Gear	.. ..	30
Top Gear	.. ..	43

- DON'T** neglect to clean the filter every 3,000 miles.
- DON'T** start off in a higher gear than is necessary, whilst this may save a change of gear, it is bad for the clutch.
- DON'T** use your brakes harshly, it is bad for the passengers, tyres and the car as a whole.
- DON'T** neglect your tyre pressures—this will save you money. See page 17.
- DON'T** omit to readjust and focus your head lamps if they have become incorrectly adjusted. You will get more pleasure when driving at night and will not inconvenience other road users.
- DON'T** forget to switch off the ignition and put the handbrake on when the car is at rest.
- DON'T** neglect the level of the acid in the accumulator and don't overflow.
- DON'T** forget to push the knob controlling reserve petrol supply when filling the tank, if you have been using your reserve supply.

## GENERAL UPKEEP

**Regular Inspection.** The oil level in the engine sump must be maintained at correct level. (The dipstick should be checked frequently and the oil level kept up to the top mark.) To inspect oil level, withdraw dipstick and wipe clean. Replace and again withdraw, when the level will be indicated by the oil film retained on the dipstick.

It is useless to check the oil level for some minutes after the engine has been running, due to the fact that a large quantity of oil will not have drained back to the oil base; the oil level should be checked before starting the engine each morning.

**Cooling System.** The water level in radiator should occasionally be examined and, if necessary, replenished.

It is advisable to use rain water as the use of hard water results in a deposit on the inner side of the cooling surfaces, thus reducing its efficiency.

**Ammeter Readings.** Observe that the dynamo is charging and the oil pressure gauge registering when the engine is "revved" up. It must be remembered when noting ammeter readings that with a discharged battery the ammeter will indicate a high charge rate. As the battery gets more fully charged the ammeter reading falls, and when the battery has reached a fully charged state the ammeter will indicate not more than a few amperes on the charge side. After starting, particularly from cold, the driver will note a fairly high charging current for about the first half hour. Thereafter it falls to the customary trickle charge for a fully-charged battery.

The acid level in the battery, which is accessible by lifting the bonnet must be checked at least once a month.

1. The acid should be kept level with the top of the separators.
2. Use only distilled water when replenishing. Do not overflow or the acid may splash out and cause damage.
3. Keep the filler plugs screwed tight to prevent leakage of acid.

Tyre pressures should be checked weekly. The correct pressures are given on page 17.

When the dynamo output is insufficient to charge the battery, the red warning light appears, indicating that current is being drawn from the battery. **The ignition switch should never be left on with the engine stationary for more than a few moments.** The ignition red warning light serves as a reminder when this has been forgotten.

We recommend owners to use a non-corrosive anti-freeze mixture in order to protect the cooling system during frosty weather and reduce corrosion to a minimum. Drain water away and replace with the anti-freeze solution, which should have been well mixed in a separate vessel in the recommended proportion. If this is attended to, particularly when the car is new, corrosion will be checked and result in a clean cooling system.

Note. Whilst the engine is warming up from cold, no water circulates through the radiator until the valve in the thermostat opens, consequently there is a risk of freezing the radiator in frosty weather unless an anti-freeze is used.

With this anti-freeze in the cooling water it is unnecessary to drain the system, even in the coldest weather, and one filling lasts the whole winter.

The anti-freeze mixture does not evaporate, therefore it is only necessary to top up in the usual manner. Only fill up to within 1 in. of overflow.

We recommend "SMITH'S BLUECOL" or "VOCO ANTI-FREEZE".



## GENERAL UPKEEP

When an anti-freeze mixture is not used and the water in the system is drained as a precaution against frost, it is essential that the drain plug at the rear of the cylinder block is also removed.

**New Engines.** When the car is new, the engine may seem to be somewhat stiff, due to the bearings being a good fit. This will continue for the first 2,000 miles, during which time the engine will become gradually "run-in" (with proper use). The power will gradually improve as the car is used.

It is inadvisable to drive a new car fast, or to run the engine at high speed in the low gears. The good and lasting bearing surfaces obtainable by careful running-in are well worth the patience required to drive the car only at moderate speed for the first 500 miles.

We have found the use of an upper cylinder lubricant to be of advantage, particularly in new engines, and recommend the use of such a lubricant until the engine is thoroughly "run-in". The lubricant should be mixed with the petrol in the proportions given on the container, and it may be used with advantage throughout the "life" of the car.

**An Automatic Thermostat** is fitted in the top water pipe. It comprises a main outlet valve normally held open by a bellows, the expansion of which is controlled by the temperature of the water leaving the cylinder head. When the engine is cold, and the main valve closed, a by-pass pipe leading to the water pump is brought into action automatically, and the water flows in a closed circuit without passing through the radiator. By this means the engine is allowed to retain part or all of its own heat instead of dissipating it through the radiator; when, however, the engine gets warm, the valve partially opens and controls the flow of water to the radiator. The action of the thermostat reduces the time required to "warm up" the engine.

## LUBRICATION

The lubrication is one of the most important subjects in connection with the upkeep of a car, and careful attention to the following instructions will be amply repaid by the results obtained.

**Engine.** The working parts of the engine are lubricated by oil drawn from the sump through filters by the gear type pump and delivered under pressure to the crankshaft journals, crankpins, gudgeon pins, camshaft bearings, and valve rockers.

The pistons are lubricated by means of a hole drilled in the shank of the connecting rod, which throws a jet of oil on to the cylinder walls.

The correct oil level in the sump is indicated by a mark on the dipstick, and it is advisable to examine this every 200 miles and replenish up to the top mark. The regular addition of oil not only maintains the correct level, but tends to keep up the quality of the lubricant, although gradual deterioration takes place until it becomes advisable after 3,000 miles to drain the sump and refill with fresh oil. The oil will drain more freely when the engine is hot and thus carry out the sediment more easily.

The pump body is provided with a large filter which surrounds the oil pump; this should be cleaned in petrol and allowed to dry each time the sump is drained. It is advisable to remove the sump every 10,000 miles and thoroughly clean out with petrol. Dry off with a smooth rag, taking care not to let any portions of the rag remain, and leave for a few minutes whilst the remaining film evaporates before replacing the sump.

## LUBRICATION

**The Tecalemit Oil Cleaner** is interposed in the main oil circuit and filters all the oil before passing to the bearings. It is important that the filter is cleaned every 2,500 miles and the element replaced every 5,000 miles.

To remove the element for cleaning, undo the large nut at the top of the filter body and the filter cylinder will then come away together with the element. These should be well washed in petrol and replaced.

A balance valve is incorporated in the body of the filter which allows the oil to pass straight into the bearings if the filter should become choked or cleaning be overdue. It is dangerous, however, to run for any length of time with the filter out of action.

A special design of relief valve is incorporated in the filter body, which controls the pressure in the main oil circuit. This is set to give between 60 and 40 lbs. with the oil hot. To effect an adjustment, slack off the nut and turn in the screw half a turn. Retighten the lock nut.

Do not attempt to clean out the sump with paraffin or petrol unless the sump is previously removed, as any small quantities remaining may cause damage to the working parts.

Special flushing oils are obtainable for the purpose of washing out the engine sump before refilling with fresh oil. This type of oil has very poor lubricating qualities, but it does help to clean out the sump and cannot do damage such as may be caused if paraffin were used. The cost of the flushing oil is similar to that of paraffin.

The flushing oil may be used without removing the sump.

Before draining the oil, it is advantageous to run the engine to warm the oil.

**First 750 Miles.** During the running-in period a certain amount of foreign matter is likely to collect in the oil. We therefore recommend that the oil be drained and completely renewed at the end of this period. This note also refers to the gearbox. In the case of the engine, it is well worth while to remove the sump and thoroughly clean out.

**Ignition Distributor.** The distributor must be lubricated every 2,500 miles as follows:

**Shaft.** Some types of distributor are provided with a lubricator, through which one or two drops of thin machine oil must be added.

**Cam Bearing.** Withdraw the moulded rotating arm from the top of the spindle by pulling it off, and add a few drops of thin machine oil. Do not remove the screw which is exposed to view on some types, as there is a clearance between the screw and the inner face of the spindle through which the oil passes to lubricate the cam bearing. On distributors having a hole drilled through the spindle, oil must be added through and around the hole as, in addition to lubricating the cam bearing, oil also passes to the shaft.

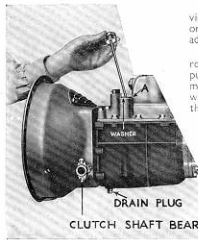

Gearbox (showing dipstick).

## LUBRICATION

**Cam and Contact Breaker Pivot.** Give the cam and the pivot on which the contact breaker works a light smear of Mobilgrease No. 2.

**Automatic Timing Control.** The moving parts of the automatic timing control must be lubricated with a good quality medium-grade engine oil. To render the control accessible, remove the distributor moulding, lift off the rotating distributor arm, and then remove the contact breaker base by withdrawing its securing screws. Take care to refit the base in its original position.

**Dynamo and Starter.** As the bearings of the dynamo are packed with grease before leaving the works, they will require little attention, excepting as described under the mileage and maintenance instructions.

**Gearbox.** The correct oil only should be used to fill up the gearbox. The use of very thick oils or grease will spoil the operation of gear changing. To fill up, remove the filler plug. The dipstick extends below the plug. To check the oil level, wipe the stick and then insert, pushing the dipstick home.

**Water Pump.** Ordinary grease dissolves in hot water and is thus able to escape into the cooling system if too much is forced into the water pump grease nipple. This may eventually result in a clogged radiator. Don't give more than two or three strokes of the grease gun every 500 miles.

**Rear Axle Lubrication.** Access to the rear axle is made by lifting the floor of the luggage boot at the rear of the car. A single plug is situated in the rear cover which also acts as an oil level. As the orifice is in the horizontal position, the axle is most easily filled up by the use of a syringe.

It is important that one of the special hypoid oils recommended on the opposite page should be used. Every 5,000 miles, drain the axle by removing the plug in the bottom and fill up with fresh oil. The capacity of the axle is two pints. Owing to the special nature of the hypoid lubricants, additions of new oil must not be made to the old oil. When the level is found to be low, always drain completely and refill.

Rear wheel hub bearings are lubricated by a grease gun. The nipples are situated on top of the axle behind the brake drum and are accessible over the top of the brake drum when the rear wheel is removed or, if preferred, can be reached through the floor of the luggage locker.

**Propeller Shaft Universal Joints.** These are of the needle-roller bearing type and sufficient lubricant is packed into the bearings to last for the life of a car in normal use.

A nipple is fitted to the sliding end of the shaft, for lubrication of the splines. This should receive attention with the grease gun every 2,000 miles, using heavy grease as recommended.

**Front Axle.** Nipples are provided for the lubrication of the swivel pin bearings. The hub bearings are lubricated by means of the grease gun, the nipple on each hub being exposed when the wheel is removed.

**Steering.** The steering gear box should be occasionally checked for oil level and replenished if necessary. Use the grease gun for the steering ball joints. The latter should be given regular attention, as the duty of these joints is high. For the steering box use only the recommended oil.

**Controls, etc.** There are several small control joints which should be given occasional attention with the oil can.

**Oil Guns.** We supply one oil gun in the tool kit, but the owner is advised to obtain an additional gun, for use as a grease gun. This will facilitate chassis lubrication. However, the gun supplied may be used for grease or for oil as required.

## RECOMMENDED LUBRICANTS

Component	Vacuum "Mobiloil"	Wakefield	"Shell"	Essolube	Price's
Engine—Winter ...	Mobiloil A.	Castrol X.L.	Double Shell	Essolube 30	Motorine M.
Summer ...					
Gearbox ... ..	Mobiloil A.	Castrol X.L.	Double Shell	Essolube 30	Motorine M.
Front Axle Swivels, Steering Joints, Front Spring Eyes ... ..	Mobiloil C.	Castrol S.T.	Shell Spirax	Essolube Gear Oil (Heavy)	Motorine Battersea A.
Rear Axle and Steering Box ... ..	Mobiloil G.X.	Castrol Hi-press (Light)	Shell Spirax G.P. 90	Essoleum Expee 90	Motorine Hypoid
Water Pump, Fan, Propeller Shaft Spine, Wheel Hubs ...	Mobilgrease No. 4	Castrolseal (Heavy)	Shell R.B. Grease	Esso Grease	Belmoline C.
Small Control Joints and Oil Cups (Oil Can), Brake Linkage	Mobiloil A.	Castrol X.L.	Double Shell	Essolube 30	Motorine M.
Upper Cylinder Lubricant ... ..	Gargoyle Upper Cylinder Lubricant	Wakefield Castrollo	Shell Upper Cylinder Lubricant	Essolube 20	Motorine U.C.L.

**Upper Cylinder Lubrication.** We recommend the use of an upper cylinder lubricant until the engine is thoroughly "run-in". This lubricant is suitable for mixing with the petrol and is thus drawn into the combustion chambers through the carburetter. It is a valuable lubricant for use in cold weather.

**Colloidal Graphite** mixed with the engine oil in quantities recommended by the manufacturers has been shown to give beneficial results during the "running-in" period of the engine.

## CARE OF THE TYRES

There are a number of points in the care of the tyres which, if attended to, will prolong the life and prevent premature failure. These points are listed below and careful attention to them will be well repaid.

1. Maintain the correct inflation pressure by weekly tests with a "Schrader" gauge. The maintenance of correct tyre pressure is a large factor in tyre life. Tyres lose their pressure due to diffusion, even though there is no porosity or leakage due to a puncture or faulty valve. The loss varies from 1 to 3 lbs. per sq. in. per week and must be made up if the tyre is to give proper service.
2. Examine the tyres occasionally for flints or other road matter which may have become embedded in the tread. If the car is driven where tacks or short nails may be picked up, these also may be found buried in the tread. If these are left in, they may eventually work through the cover and puncture the tube. Fill up any larger holes with a suitable compound. When cuts reach the casing it is always economical to have a vulcanised repair carried out by a competent operator.
3. Oil should not be allowed to get on the tyres. If any should accidentally do so, clean off by using petrol sparingly.
4. The car is provided with powerful brakes, and it should be remembered that the forces of retardation are applied through the tyres. Fierce application of the brakes will cause rapid tyre wear.
5. Do not drive over sharp edged curbs or "bump" them with the side of the tyre, as this is liable to fracture the cotton tyre casing, and in the latter case upset the front wheel alignment.
6. If the front wheels are not properly aligned, there will be a tendency to wear the front wheel tyres unduly. The front wheels are set with a "toe-in" of  $\frac{1}{4}$ ", and should this at any time be upset, it can be restored by adjustment of the steering track rod, although if the misalignment is due to a bent steering lever, this should first of all be replaced.

"Toe-in" is the amount by which the front wheels are inclined from parallel, and is measured at the wheel rims. To take this measurement, set the steering in the "straight ahead" position and measure the distance between the two front rims at a height above the ground equal to that of the wheel hubs. Take this measurement both in front of, and behind the axle bed. The former measurement should be  $\frac{1}{4}$ " less than the latter.

### FITTING AND REMOVAL INSTRUCTIONS FOR WIRED TYPE TYRES ON WELL BASE RIMS

Inextensible wires are incorporated in the edges of wired type tyres. Therefore, do not attempt to stretch the wire edges of the tyre cover over the rim edge.

Force is entirely unnecessary and may be dangerous, as it merely tends to damage the cover edges and serves no helpful purpose.

## CARE OF THE TYRES

Fitting or removing will be quite easy, if the wire edges are carefully adjusted into the rim base; if it is not found to be easy, the operation is not being correctly performed.

**To Remove Tyre.** Remove all valve parts, and push both cover edges into the base of rim at the part diametrically opposite the valve, then lever the cover edges near the valve over the rim edge.

**To Fit Tyre.** Push one edge of the cover over the edge of the rim. It will go quite easily if the first part put on is pushed right down into the rim base.

Very slightly inflate the inner tube—do not distend it—place it in the cover, with the valve through the hole in the rim. (Take care that the valve, which is fitted in the side of the tube, is on the correct side of the rim.)

Fit the second edge of the cover, commencing at a point diametrically opposite the valve, and pushing the edge down into the base of the rim.

Small levers may be gently used to ease the last few inches over the rim edge. Be careful not to nip the tube.

Whilst inflating, see that the edges of the cover are seated evenly round the rim: check by the line on the cover.

You cannot pull the cover edge at "A" over the rim edge until the cover edge at "B" is pushed off the rim shoulder "C" down into the well "D," then the cover edge at "A" comes over the rim easily.

Remember the cover edges are inextensible—force will only damage the cover and cannot stretch the edge.

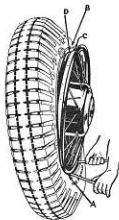

### CORRECT TYRE PRESSURES.

$\frac{1}{2}$  Litre Jaguar .. .. .

Inflation Pressure (lbs. per sq. in.)	
Front	Rear
28	28 (5.25—18 tyres)

## BRAKES

Girling brakes are fitted to all four wheels. These are operated by pedal through a special linkage, the hand lever being connected to the rear wheel brakes.

The linkage is so designed that in the event of a failure of any part of the system, the brakes of two road wheels on one axle will still be operative.

The linkage is fully compensating and once this is correctly set there should be no need for alteration. The only adjustment that is normally necessary is to turn up the adjuster cone on each brake drum, which compensates for wear. The brake adjuster is shown on the front axle on page 21. To carry out this adjustment, it is not necessary to jack the car up, although the adjustment of all brakes will be much more easily carried out on a high lift service jack than where the car remains standing on the ground level.

To make the adjustment, turn the adjuster cone with a spanner in a clockwise direction. This will cause it to move in slightly and expand the fulcrum ends of the brake shoes. Turn this up as far as it will go and then slack back one click. All four brakes should be treated in a similar manner. When this is completed, and before testing on the road, give one firm application to brake pedal, in order to make sure the shoes have lined up properly.

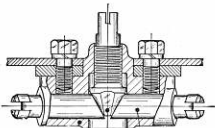

**Description of Brake Mechanism.** The brake shoes are pressed from solid drawn T-section steel and are operated by the expander shown below. The hardened steel cone (1), which is actuated by the pull rod (2), causes the plunger (3) to move outwards. Hardened steel rollers (4) are interposed between the cone and the plungers to reduce friction to a minimum. The plungers engage directly with the brake shoe webs. The whole expander mechanism is enclosed in a die-cast housing (5), which retains a supply of lubricant and protects the moving parts from mud, etc. This housing is slidably attached to the back plate (6) by studs and spring washers (7) (which provide a slight frictional contact). The housing does not withstand any of the stresses set up by braking, as it virtually floats between the brake shoes.

In view of this fact, it will be realised that the brake shoes are self-centring under the influence of the brake shoe pull-off springs. It should be noted that the rollers (4) are freely mounted and roll up grooves in the plunger and down the inclined face of the cone. This free mounting gives the cone twice the travel of the rollers and thus doubles the overall leverage, due to the cone angle. Pin (8) retains the plunger in the housing. This type of shoe expander provides a high step-up ratio and multiplies the low input effort of the pull rods very considerably (actually 6.33 to 1).

**Relining Brakes.** When the brake linings have worn down nearly to the rivets, it is necessary for new linings to be fitted. Remove wheels and brake drums, it will then be found by stretching the pull-off springs that the shoes can be lifted clear without removing the back plates. We strongly advise that the shoes are returned to the works for relining or the supply of replacement shoes, an allowance being made for the used shoes. This is advisable, as a special type zinc-bonded lining is employed and, in addition, the shoes are ground after the lining has been riveted in position. When the new shoes are obtained, fit up with the return springs. Place one shoe in the slots in the plunger and the adjuster, the second shoe can then be sprung into position. The shoes, front and rear, are interchangeable. When this

## BRAKES

is done, make sure that the cone (1) on each brake returns at least flush with the housing. If this is not the case, it indicates that the linkage needs alteration. This will be dealt with in a later paragraph.

Assuming the cones are correct, replace the brake drum and tighten up the adjuster to its fullest extent, making an application to the brakes through the pedal to be sure that the cone seating has moved into the correct position. Now slack off the adjuster two to three notches. This is necessary because the brake linings, when first fitted, have a tendency to swell in the drums. The car should be taken out and the brakes used vigorously, so that the shoes are well bedded down on to the drum. It will be found that while doing this the pedal travel will be considerably reduced. The brakes should then be readjusted as previously described and turned back one notch only. Although not essential, it is always recommended that when new brake shoes have been run-in, the drums should be again removed and the dust which has come off the new linings blown out. No petrol or paraffin must be applied to the brake linings for the purpose of cleaning, as this seriously affects the coefficient of friction of the lining.

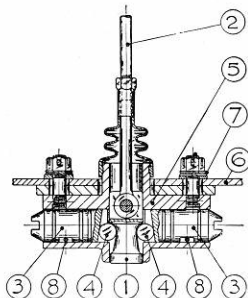

## BRAKES

**Brake Linkage.** When it is found necessary to make an adjustment to the operating rods, the following instructions, in conjunction with the diagram, should be carefully followed.

The pedal is the fully-floating type, which eliminates the frictional resistance of the loaded pivot. The apparent pivot link on the brake pedal only serves to carry the weight of the pedal and linkage and is not used as a reaction point. It is essential, therefore, that the correct positioning and the method of adjustment is closely adhered to.

1. Starting at the front axle, remove the drums and make sure that the cones are coming fully out, that is, the face of the cone comes at least flush with its housing.
2. Now adjust the front rods to such a length that the operating pin for the pull rod will come  $1''$  maximum,  $\frac{3}{8}''$  minimum in front of the horizontal (see diagram). Carry out the same operation on the back brake pivot and rods, excepting that the dimension should be  $1\frac{1}{2}''$  maximum,  $1\frac{1}{8}''$  minimum to the rear of the horizontal.
3. Obtain a steel disc,  $1\frac{3}{16}''$  diameter with a  $\frac{3}{8}''$  diameter hole. This is slid on to the brake stop pin, as shown in the sketch. The front pull rod is now put on and adjusted to such a position that the top bolt of the pedal pad fixing is positioned  $3\frac{3}{4}''$  behind the pivot of the brake supporting link.
4. Now check the position of the swinging lever on the third cross member. The centre of the operating pin should be  $1''$  behind the vertical with the brakes off, and the rear rod should be adjusted so that this position is obtained. Make sure that the handbrake striking pin is quite clear of the lever while the adjustment is being made. The main rod can now be fitted up and adjusted at the front end to the required length. It is most important that the dimensions and settings of the pedal and levers are adhered to closely, otherwise the effectiveness of the system is entirely lost. When the adjustment is finished, do not forget to remove the adjustment disc from behind the pedal, and recheck clevis pins to make certain all split pins are in position.

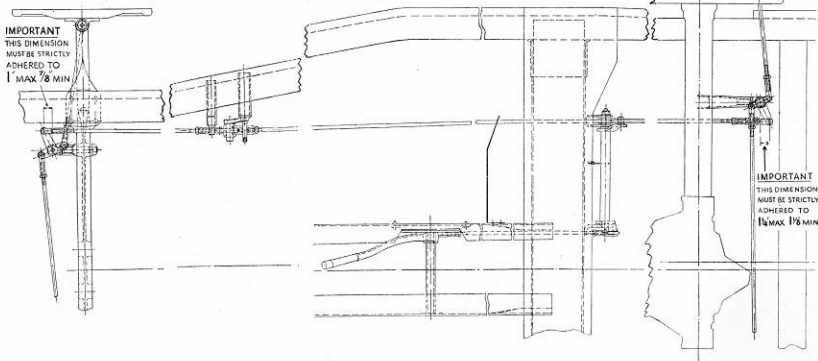
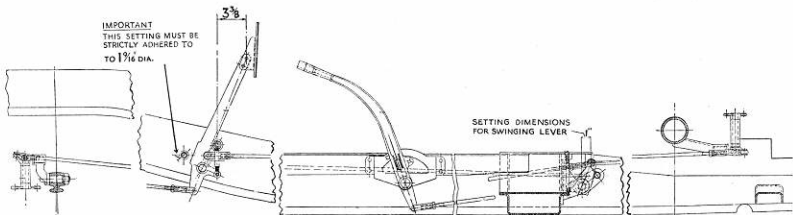

## CARBURETTER

The carburetter is S.U. type with a hand-controlled jet position. It is correctly adjusted when the car leaves the works and further adjustments, except to mixture strength, should not be necessary. If, however, the setting has been lost, due to cleaning or careless adjustment, providing the instructions given below are carefully followed, the original setting can be restored.

The principle of the carburetter is a variable choke which is operated by means of a sliding piston, to which is attached a tapered needle valve. The piston is raised and lowered in proportion to the variation of pressure in the induction manifold. As the piston is raised, the tapered needle valve opens, metering the fuel in the proportion required by the engine. The jet in which the needle works is a fixed size. The needle graduation is very carefully settled on the test bench to suit the particular type of engine. It will, therefore, be seen that it is inadvisable to change the needle supplied by the makers, except in cases where the needle has been damaged, and then it must be changed for another of the same type. The type of needle will be found stamped on the thick end.

**To Tune and Synchronise Carburetters.** Before attempting to tune the carburetters, the engine must be warmed up to its normal running temperature, in this case between 50° and 70° C. There are only two ways in which the carburetter setting may need correction, they are (a) amount of throttle opening for slow running, and (b) the mixture strength at this position.

For (a)—Screw outwards the spring-loaded throttle adjusting screw until a thin piece of paper can just be passed between the end of screw and stop web on body, with the throttle in the closed position; then turn the screw half a turn inwards. As, presumably, the mixture strength has not yet been dealt with and is, therefore, only approximately right, it will probably be necessary to have a fairly fast slow "run" to keep the engine going, in this case it will be necessary to drop the slow "run" speed after the mixture strength has been settled. This only means slackening back (outwards) the throttle stop screws a quarter or half a turn until the desired speed is reached.

For (b)—First check the needle position in each piston. This can be done by removing the two screws holding the suction chamber in position, the suction chamber can then be lifted off and the piston removed. At the side of the piston will be seen a set screw; when this is slackened the needle can be withdrawn. The correct position of the needle is with its shoulder flush with the face of the piston. When replacing, care should be taken that the key-way at the side of the piston registers with the key in the body. Great care should also be taken to see that all machined faces and parts are kept scrupulously clean.

The jet adjusting nut on the carburetter should then be moved until the best position is obtained. Turning up the screw weakens the mixture, and unscrewing enriches it. When making this adjustment, observe carefully that the jet head follows the movement of the nut.

## CARBURETTER

When this has been set to what is believed to be the best position, check by lifting the piston with a thin screwdriver or pencil about  $\frac{1}{16}$ ". If this makes the engine run irregularly, due to weakness, it indicates that the mixture is correct. If, on the other hand, it improves the running of the engine, it indicates that the mixture is rich. When the mixture is correct, the exhaust beat should be regular and even. If it is irregular, with a splashy type of misfire and a colourless exhaust the mixture is too weak. If there is a rhythmic or regular type of misfire in the exhaust beat, together with a blackish exhaust, then the mixture is too rich.

**Hydraulic Piston Damper.** On the  $\frac{1}{2}$  Litre carburetter a hydraulic piston damper is fitted. This is located in the hollow piston rod and attached to the oil cap nut. It consists of a plunger with a one-way valve and its function is to give a slightly enriched mixture by preventing the piston rising too quickly when the accelerator is snapped open. The only attention necessary is to keep this supplied with thin oil. It should not, however, require attention more than about once a month. Indication that the oil chamber requires filling is given if spitting back is experienced when the throttle is opened quickly.

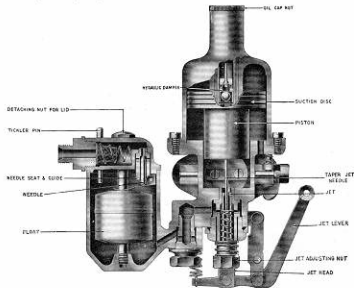

**Centring the Jet.** This is an operation which requires very careful handling. Therefore, do not make an adjustment here unless it is definitely established that the position is incorrect.

If the piston is lifted by hand it should fall freely and hit the jet bridge with a slight click. If it does not, it means (except instances where the piston is sticking due to excessive deposit in the suction chamber or around the piston) that the needle is catching on the side of the jet, this upsets the whole carburation and should be remedied by recentering the jet on the needle.

## CARBURETTER

### To do this:

1. Reposition the needle approximately  $\frac{1}{16}$ " lower (further out) than normal and replace suction chamber and piston.
  2. Screw the jet adjusting nut up to its topmost position.
  3. Slacken off the large hexagon jet screw about one-third to half a turn.
  4. After removing oiler brass cap in top of suction chamber, gently push piston rod downwards, this will position the jet exactly central with needle.
  5. Tighten up hexagon jet screw.
- Return needle to normal position. Then replace suction chamber and piston. It will then be necessary to lower jet adjusting nut to the best position for slow running. Do this tuning when engine is warm.

After adjusting the idling in this way, the dome nut should be replaced, care being taken that the washer is not mislaid when the dome nut is removed.

**Fit of the Piston in Suction Chamber.** The fit of the suction piston in the suction chamber controls the piston lift and is a point to watch. This is not measured mechanically, but by "air leak" past this clearance.

This is done by holding the piston upside-down in the right hand with the finger or thumb over the small air hole (which leads inside), whilst the left hand supports the suction chamber, which is pushed towards the piston as far as possible. If the left hand is now removed from the suction chamber, this part will slowly fall by its own weight away from the piston, the time taken to fall depending on the clearance of "air leak" past the large diameter, this time is three to four seconds, two seconds is definitely fast.

## CAUSES OF BAD RUNNING

There are a number of faults which can cause the engine to run badly. If the trouble is actually due to carburation, it is likely to come under one of the following headings:

1. Piston sticking (see Paragraph 1).
2. Dirt or water in the carburetter (see Paragraph 2).
3. Float chamber flooding (see Paragraph 3).
4. Float needle sticking (see Paragraph 4).

The trouble may, however, be found to be due to one of the following causes:

Loss of compression on one or more cylinders.

Plug points too far apart, causing misfiring and popping in the carburetter when the engine is on full throttle pulling hard on hills; also difficult starting from cold.

Oily plugs, causing misfiring.

Faulty ignition, bad starting and misfiring.

Sticky valves, causing misfiring and popping in exhaust and through the carburetter.

Blockage or air lock in petrol pipe, causing carburetter to give symptoms of weak mixture, i.e., lack of power and popping back through the air inlet.

This can be tested by detaching petrol pipe connection at float lid to see if there is a free flow through the pipe.

Bad joints between the carburetter and the engine will cause bad starting and engine will not idle.

## CARBURETTER

### PISTON STICKING

**Paragraph 1.** The suction piston comprises the piston, forming the choke, the needle and suction disc; into this is inserted the hardened and ground piston rod which works in the bearing of the suction chamber. The piston rod running in the bearing is the only part which is in actual contact with any other part—the suction piston and needle having clearance fit and, consequently, should not cause sticking. If this does occur, the whole assembly should be carefully cleaned and the piston rod only should be lubricated with a spot of thin oil. A sticking piston can be ascertained in a few seconds by inserting a finger in the air intake and lifting the piston, which should come up quite freely and fall right on to its seat when released.

### WATER OR DIRT IN CARBURETTER

**Paragraph 2.** When this is suspected, lift the piston with a pencil. The jet can then be seen. Flood the carburetter by depressing tickler pin and watch the jet; if the petrol does not flow through freely, there is a blockage. To remedy this start the engine, open the throttle, block up the air inlet momentarily without shutting the throttle; keep throttle open until the engine starts to race. This trouble seldom arises with the S.U. carburetter owing to the size of the jet and the petrol ways. When it does happen, the above method will nearly always clear it. Should it not do so, the only alternative is to remove the jet. This, however, should on no account be done unless it is absolutely necessary, as when refitting it has to be carefully centred to the needle, and it is practically impossible to assemble this part correctly unless it is first thoroughly understood how this is carried out.

### FLOAT CHAMBER FLOODING

**Paragraph 3.** This can be seen by the petrol flowing over the float chamber and dripping from the air inlet when the engine is running, and is generally caused by grit between the float chamber needle and its guide; this can usually be removed by depressing tickler pin, which allows the incoming petrol to wash the grit through the guide and into the float chamber.

### FLOAT NEEDLE STICKING

**Paragraph 4.** If the engine stops, apparently through lack of fuel when there is plenty in the tank, the probable cause of this is a sticking float needle. An easy test for this is to disconnect the pipe from the pump to the carburetter and operate the pump by means of the hand primer to see if fuel is delivered. If the car is fitted with an electric petrol pump, disconnect the pipe from the pump to the carburetter, switch on the ignition and see if fuel is delivered. If it is, starvation has almost certainly been caused by the float needle sticking to its seating, and the float chamber lid should, therefore, be removed, the needle and seating cleaned and refitted. At the same time, it will be advisable to clean out the entire fuel feed system, as this complaint is caused by foreign matter in the petrol, and unless this is done it is likely to recur. It is of no use whatever to replace any of the component parts of the carburetter, and the only cure is to make sure that the petrol tank and pipe lines, etc., are entirely free from any kind of sticky substance capable of causing this trouble.



## PETROL PUMP

An A.C. Mechanical Type Pump is fitted which draws petrol from the rear tank and feeds to the carburetter. Reference to the diagram on the opposite page and the following notes will give a good idea of the way in which the pump works.

By revolving shaft (G) the eccentric (H) will lift rocker arm (D), which is pivoted at (E) and which pulls the pull rod (F), together with diaphragm (A) downward against spring pressure (C), thus creating a vacuum in pump chamber (M).

Fuel from the rear tank will enter at (J) into sediment chamber (K) and through filter gauze (L) and suction valve (N) into pump chamber (M). On the return stroke, spring pressure (C) pushes diaphragm (A) upward, forcing fuel from chamber (M) through pressure valve (O) and opening (P) into the carburetter.

When the carburetter bowl is filled the float in the float chamber will shut off the inlet needle valve, thus creating a pressure in pump chamber (M). This pressure will hold diaphragm (A) downwards against the spring pressure (C) and it will remain in this position until the carburetter requires further fuel and the needle valve opens. The rocker arm (D) is in two pieces, the outer operating the inner one by making contact at (R) and the movement of the eccentric (H) is absorbed by this "break" when fuel is not required.

Spring (S) is merely for the purpose of keeping rocker arm (D) in constant contact with eccentric (H) to eliminate noise.

### SERVICE HINTS

If the pump fails to supply petrol to the carburetter, the following points should be attended to :

First, check the petrol tank to make sure that the petrol is available. If the level is low, operate the reserve tap.

If the pump still fails to supply petrol, this is probably due to a leaking connection or, possibly, a cracked pipe. Check all unions and examine the pipes, particularly at any acute bends. Another possible source of trouble is a loose filter cover on the top of the pump. Remove the top cover by undoing the set screw in the top, examine the cork gasket and make sure that this lies flat on its seat and is not broken or unduly compressed. Remove the filter screen and clean.

If attention to these points fails to cure the complaint, it is advisable to take the pump to an A.C. Service Station for examination.

**Leakage of Fuel at Edge of Diaphragm.** This is due to the cover screws having become loose. These should be carefully tightened down alternately, giving each screw a quarter of a turn until they are all fairly tight. Do not disassemble the pump body.

In cases where a new diaphragm or any major service has to be carried out on the pump, we recommend this to be done at a Service Station, where equipment for dealing with this matter is available.

It is important that when the cover of the pump is replaced the pull rod shall be at the top of its stroke, in order to ensure sufficient flexing of the diaphragm to allow the full working stroke of the pump.

## PETROL PUMP

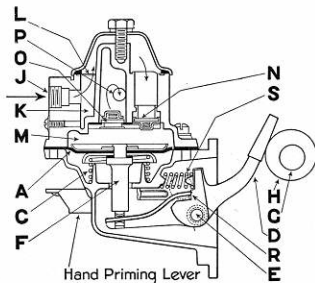

Fuel Pump—Section

## ELECTRICAL SYSTEM

A Lucas 12-volt earth return (or one wire) lighting and starting set is fitted, consisting of dynamo, voltage regulator, automatic cut-out, starter, distributor and coil, switches, lamps, ammeter, screen wiper, horn, trafficators, fuses and battery.

In the "earth return" or "single pole" system the negative battery terminal is connected to the starter switch and the positive terminal to the frame. A single cable leads the current from the starter switch to the starter, which is "earthed" to the frame. In like manner, a single wire leads current from the "live" terminal of the starter switch through the ammeter and switches to the various points, which are also "earthed" to the frame. Thus when current flows along a wire it returns through the metal portions of the chassis to complete the circuit.

As the frame parts are not insulated, one cable should be disconnected from the battery terminal before removing any electrical unit, otherwise there is risk of a serious "short."

**Dynamo and Combined Cut-out and Regulator Unit.** The equipment consists of a specially designed dynamo and a regulator unit which enables the dynamo to give an output which varies according to the state of charge of the battery. When the battery is discharged the dynamo gives a high output, so that the battery receives a quick recharge, which brings it back to its normal state in the minimum possible time. On the other hand, if the battery is fully charged, the dynamo is arranged to give only a trickle charge which is sufficient to keep it in good condition without any possibility of causing damage to the battery by overcharging.

In addition to controlling the dynamo output according to the state of charge of the battery, the regulator provides for an increase of output to balance the current taken by the lamps or other accessories when they are switched on.

The regulator also causes the dynamo to give a controlled boosting charge at the beginning of a journey, which quickly restores to the battery the energy which has been taken from it in the operation of starting. After about 30 minutes' running, the output falls to a steady rate best suited to the particular state of charge of the battery.

The cut-out is operated by the dynamo voltage, and when due to increasing speed the dynamo develops sufficient voltage to charge the battery, the cut-out points make contact and so allow current to flow from the dynamo to the battery. When the engine slows down, the dynamo voltage falls below that of the battery and the reverse action takes place, i.e., the cut-out opens and thereby prevents the battery from discharging itself through the dynamo. Both the regulator and the cut-out are accurately set before leaving the works, and do not need any adjustment.

**Electric Starter.** The starter pinion automatically engages with teeth on the flywheel when operated. When the engine fires, the flywheel overruns the starter pinion and automatically throws it out of engagement.

A spring loaded shock absorber is incorporated for the purpose of reducing the initial shock of pinion engagement.

The starter is provided with an extended shaft having a squared end, so that it can be rotated by means of a spanner in the remote possibility of the pinion becoming jammed in mesh. Access is obtained to the squared end by pulling off the metal cap, which is secured by two screws.

If the pinion on the starter motor does not engage with the flywheel teeth, examine the screwed sleeve on the armature spindle to see that it is free from dirt; if necessary wash over with paraffin. Occasionally give it a few drops of thin machine oil.

**Ignition.** The coil ignition set consists of a coil mounted close to the combined distributor and contact breaker. The red warning light incorporated in the instrument panel serves as a reminder that the ignition has not been switched off when the engine is at rest. If the ignition is left on under these circumstances,

## ELECTRICAL SYSTEM

there is danger of current flowing through the coil and distributor and so discharging the battery. Although the red light may show when the engine is running slowly, it is not then a danger signal, but simply indicates that the dynamo is not generating sufficient voltage to charge the battery.

After long service the warning lamp bulb may burn out, and although this will not affect the ignition, the bulb should be replaced at the earliest opportunity by one of the same size and type.

**Fuses.** The cut-out and regulator unit houses the following fuses:—

**Fuse marked "AUX. A".** This fuse protects the accessories which are connected so that they operate whether the ignition switch is on or off.

**Fuse marked "AUX. B".** This fuse protects the accessories which are connected so that they operate only when the ignition is switched on (e.g., Petrol Gauge, Trafficators, Fog Lamps, etc.).

**Fuse marked "S. & T".** This fuse protects side and tail lamps.

**Fuse marked "H".** This fuse protects head lamps.

If all the units protected by one of the fuses fail, inspect the fuse.

If the fuse has blown, examine for faulty wiring and replace by one of the spare fuses provided. If the new fuse blows, the cause of the trouble must be found, and we advise that the equipment is examined by one of Lucas Service Depots.

Never fit any fuse other than the standard Lucas fuse as originally fitted.

See wiring diagram on page 32.

**Battery.** The battery forms a six cell single unit carried under the bonnet. Capacity 50 amp. hrs. (10 hour rate).

**Head Lamps.** An electrically operated dipping reflector is incorporated in the near side lamp. The switch is conveniently mounted at the centre of the steering wheel, and when operated, causes the offside lamp to "go out" and the near side lamp to "dip". The switch at the centre of the instrument panel gives either side and tail lamps or head, side and tail lamps, as required.

The dipper unit in the near side head lamp is protected by a fuse which is mounted alongside the unit. If the equipment fails, this fuse can be examined by removing the reflector unit. To remove the unit, first remove the lamp front, then take off the cork washer. This will leave a screw-head exposed. Remove this screw and turn the reflector unit in a clockwise direction to remove it. With some lamps, the reflector can be withdrawn from its supports when the lamp front is removed.

There is also a switch connected to the brake pedal which operates the stop light, and a reversing light is operated when engaging reverse gear.

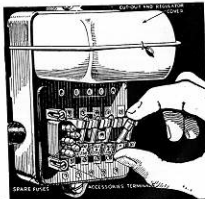

Cut-out, Regulator and Fuse Box

## ELECTRICAL SYSTEM

**Lucas Horns.** Each electric horn, before being passed out of the works, is adjusted to give its best performance and will give long periods of service without attention.

If either of the horns becomes uncertain in its action, it does not follow that the horn has broken down. First ascertain that the trouble is not due to some outside source, e.g., a discharged battery, a loose connection or short circuit in the wiring of the horn, or a blown fuse.

It is possible that the performance of a horn may be upset by the horn becoming loose on its mounting. This can be ascertained by removing the horn from its mounting and testing its note.

If, after carrying out this examination, the horns are still unsatisfactory, they may need adjustment, but this should not be necessary until the horns have been in service for a considerable period. To adjust a horn, slacken the lock nut on the fixed contact and rotate the adjusting nut until the contacts are just separated (indicated by horns failing to sound). Turn the adjusting nut half a turn in the opposite direction and secure it in this position by tightening the lock nut.

If the note is still unsatisfactory, do not attempt to dismantle the horn, but return it to a Lucas Service Depot for examination.

**"Trafficators".** These are operated by a switch at the centre of the steering column. Movement of the switch to right or left raises the corresponding signal and at the same time lifts a cam fitted underneath the switch, so when the steering wheel is returned to the straight ahead position, it pulls back the switch to the "off" position and the signal falls. Further reference to these indicators is on page 56.

Removal of bulb from "Trafficator" arm.



Should the arm fail to light up, when in operation, examine the bulb. To remove the bulb, switch on the "Trafficator", and then, whilst supporting the arm in a horizontal position, move the switch to the "off" position; withdraw the screw on the underside of the arm and slide off the metal plate; the faulty bulb can then be replaced. To replace the metal plate, slide it on in an upward direction, so that the side plate engages with the slots on the underside of the spindle bearing. Finally, secure the plate by means of its fixing screw.

Do not use the "Trafficator" with no bulb inserted as the spring holder will then make contact with the metal plate and blow the fuse.

Every two-three months, raise each "Trafficator" arm, and, by means of a brush or other suitable article, apply a drop of thin machine oil to the catch pin between the arm and the operating mechanism.

**Petrol Gauge.** An electrical gauge fitted on the instrument panel indicates the amount of fuel in the tank and is brought into operation when the ignition is switched on. A rheostat is fitted in the top of the petrol tank and connected by an arm to the float which indicates the fuel level by setting the rheostat resistance in a corresponding manner. This each level has a different electrical resistance which is suitably indicated on the gauge.

The outer terminal of the dash unit marked "Battery+" is connected to the ignition circuit in the fuse box so that the petrol gauge is operated only when the ignition is turned "On". The centre terminal marked "Tank" is connected by a

## ELECTRICAL SYSTEM

single wire to the fuse box and then to the terminal on the Tank Unit. The return circuit is accomplished through a "ground", as both the dash unit and tank unit are "grounded" in their respective locations.

Should the painter not move when the ignition is switched on, there may be a break in the wire between the dash unit and ignition switch. If the gauge shows "Full" under all conditions, there may be a break between dash unit and tank unit. Should the gauge show "Empty" under all conditions, the wires may be reversed on dash unit, or dash unit may not be "grounded". Alternatively, tank unit may not be "grounded". This calls for replacement of the unit involved. In general, service is by replacement of the inoperative unit. Do not attempt to lubricate either unit.

A reserve supply of petrol is arranged for in petrol tank, the two-way cock is operated by knob adjacent to filler cap. Push in for main supply, pull out for reserve.

### HOW TO OBTAIN THE BEST SERVICE FROM THE ELECTRICAL SYSTEM

#### Battery.

1. Keep a month inspect the acid level in each of the cells, and if necessary add sufficient distilled water to bring the level to the top of the separators.
2. Keep the terminals tight and smeared liberally with vaseline to prevent corrosion.
3. Keep the tops of the cells clean and dry.
4. Never leave the battery in a discharged condition for any length of time.

#### Coil Ignition Equipment.

1. Keep distributor clean inside and out.
2. Test contact breaker gap (fully opened) occasionally with gauge provided on ignition screwdriver. Reset if it varies appreciably from the gauge (.010" — .012").
3. Lubricate distributor every 2,500 miles. See page 13.
4. Replace high tension cables showing signs of perishing or cracking with 7 mm. rubber covered ignition cable.

#### Dynamo.

1. Keep brushgear and commutator clean. See that the brushes bear properly on the commutator. Replace badly worn brushes.
2. When car is taken down for a general overhaul, have dynamo dismantled for cleaning, adjustment and repacking bearings with lubricant. This should be done preferably by a Lucas Service Depot.

#### Lamps.

1. Keep reflectors clean. Finger marks can be removed with a soft dry cloth without injury to the highly polished surface. Do not use metal polish.
2. Use only the correct Lucas replacement bulbs. See table.
3. Focus head lamps after fitting new bulbs. The bulb holder can be moved backwards and forwards when the damping clip at the back of the reflector is slackened.
4. Keep lamps in proper alignment.

#### Particulars of Bulbs.

Lamp	Bulb	Volts	Watts
Head Lamps	Lucas No. 57 or 54	12	36
Side, Stop, Tail and Panel	Lucas No. 207	12	6
Fog Lamps	Lucas No. 87	12	60
*Ignition Warning Lamp	Lucas No. 1224M	12	2.4
**"Trafficators"	Lucas No. 256	12	3
**"Trafficator" Warning Light	Lucas No. 1224M	12	2.5
Reverse Light	Lucas No. 1	12	24
Interior and Tool Container	Lucas No. 251	12	6

\*Cars 410001 to 410750

Lucas No. 252A

2.5

5

## ELECTRICAL SYSTEM

PASTE WIRING DIAGRAM  
IN HERE WHEN RECEIVED

## ENGINE

**Sparking Plugs.** It is important that all plugs should be set to the same clearance of 0-020 to 0-025 inches. This can be tested with the gauge supplied in the tool kit.

The engine will not run smoothly at slow speeds, neither will it start easily if the gaps vary too much. It is advisable to remove, clean and set the points of the sparking plugs about every 5,000 miles, and when replacing in the cylinder head, make sure that the copper-asbestos washers are in good condition and screw the plugs firmly into position.

The normal efficient life of a sparking plug is 10,000 miles, although they will function for longer periods. Recommended plug, Champion L.10.S.

All electrical connections must be securely made, kept dry and clean. The plug connections are those most liable to come loose.

When washing the car, care should be taken that water does not remain on the coil or sparking plugs, as its presence on either may cause short-circuiting and corrosion of contact points and terminals. It is also advisable to remove the distributor cover and wipe out any water that may have collected inside.

The distributor contact breaker points require cleaning and adjusting occasionally. A small screwdriver and gauge are provided for the purpose and a thin abrasive stone may be obtained for cleaning the points, but only a few strokes with this should be necessary. When re-setting the gap, the gauge secured to the screwdriver should just fit the gap at its maximum opening, which can be found by slowly turning the engine with the starting handle. The correct gap is .010"—.012".

If only one cylinder misfires, this will probably be due to a fault in the wiring connections to that cylinder, which should be carefully examined to see that there is no breakage. If a wire should be found to be broken, a temporary repair can be made by cutting through the insulating material at the break and peeling each broken end of the wire for about  $\frac{1}{2}$ ", then twisting them into each other and finally binding with insulating tape. The repaired portion should be held clear of the metal parts to prevent short circuiting.

The firing order is 1, 3, 4, 2.

**Valve Clearances.** A clearance between the valve stem and the tappet is necessary to ensure correct closing of the valves and efficient running of the engine.

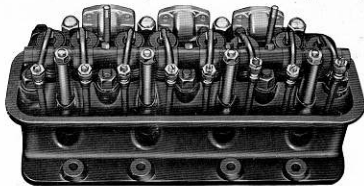

Remove rocker shaft assembly to obtain access to central holding down nuts. To tighten or slacken cylinder head give each nut half a turn only, commencing at the centre, then work outwards.

## ENGINE

The correct clearance is  $-.012"$  for both inlet and exhaust valves. A gauge is provided in the tool kit for the purpose of setting this clearance.

If a tappet becomes noisy, it can be silenced by adjusting the clearance to the correct amount. Do not set the valve clearances too small or the engine will not maintain good tune.

**Decarbonising.** The presence of excessive carbon deposit is usually indicated by falling off in power and "pinking"—when the engine is labouring on a hill or picking up on one of the high gears.

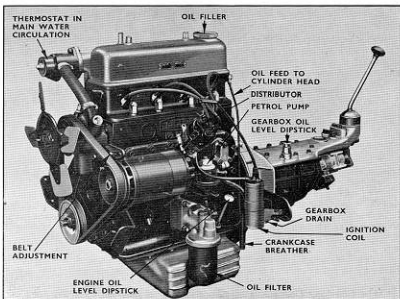

Power Unit

**Pinking** is caused by the mixture in the combustion space reaching the spontaneous ignition temperature of the fuel; this rise in temperature is due to the rise in pressure, especially on engines having a high compression ratio. If the recommended type of fuel is being used and the "pinking" becomes pronounced, then it is necessary to have the engine decarbonised.

Although not essential, a new cylinder head gasket should be fitted after the cylinder head has been removed.

It is recommended that the first decarbonising should be done at 4,000 to 5,000 miles and subsequently every 10,000 miles. This depends to some extent on quality of fuel and manner of driving if the car is operating satisfactorily, decarbonisation can often be deferred to considerably greater mileages with no detriment.

This work should be carried out by skilled mechanics, but it is possible for the owner to do this work, and it is with this object that the following remarks are given.

It is advisable to obtain a spare cylinder head gasket before attempting to remove the cylinder head.

## ENGINE

When fitting the gasket, it is important that the flat side of the gasket be placed upwards to the cylinder head so that the corrugations stand down towards the head. If this is not done, the water holes in the gasket will not correspond with those in the head and block, and the cooling of the car will be seriously affected.

Run the engine for a short period to warm it, then commence operations.

Now drain the water from the cooling system. If it is winter and an anti-freezing solution is being used, the owner may desire to preserve the cooling water for further use; if, however, the old water is discarded, do not forget to renew the anti-freezing element.

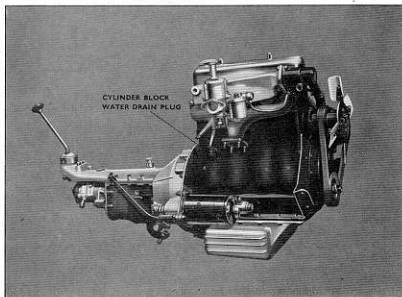

Power Unit

Remove the air cleaner, take off the cylinder head cover and top water pipe, then take off the induction pipe complete with carburettor, remove the exhaust manifold, remove the rockers complete with shaft and bearings.

The cylinder head holding-down nuts are now all accessible; care should be taken that these nuts are slackened in rotation, commencing at the centre ones and working outwards, slackening each nut only half a turn; this precaution is necessary in order that undue strains shall not be imposed on the cylinder head casting due to unequal pressures exerted by the tightening of the nuts.

The head is now ready to be lifted, and it may be found an advantage to tap the sides of the head with a wooden mallet or a hammer, with a piece of wood interposed, to break the joint. Do not damage the cylinder head joint by inserting a chisel or other instrument to break the joint. A small wooden block should be prepared, slightly smaller than the combustion space, but a little thicker. Place the cylinder head on the bench with the wooden block in one of the combustion chambers; these valve springs can now be depressed sufficiently to allow the split

## ENGINE

collars to be removed. The valves can now be taken out, but care must be taken to arrange for each valve to be assembled in its original position. Repeat this operation on each pair of valves.

Using a blunt screwdriver or similar instrument, carefully scrape the combustion chambers, taking particular care to clean around each valve seat, but do not damage the conical seating.

Remove the sparking plugs, clean and reset the points, have them tested on a Champion machine at a Garage or Service Depot.

Before starting to clean off the carbon from the piston crowns, first turn the crankshaft over by hand until any two pistons are at top dead centre, then fill the remaining cylinder bores with clean rag to prevent any chips of carbon falling into the cylinders.

Scrape the piston crowns and the carboned portions of the cylinder face, using an old screwdriver or similar blunt tool in a "chiselling" manner. Scrape clean the valve ports, but be careful not to scratch the valve seats, and when completed, wipe clean with a paraffin damped rag. Then give the starting handle a partial turn and treat the other pistons in the same manner.

When replacing the cylinder head nuts, it is most important to tighten them gradually in turn, in the sequence mentioned on page 35. This will produce an even pressure on the gasket and prevent undue strain in the cylinder head casting. If a new gasket has been fitted, it will be additionally necessary to run the engine until warm, go over the nuts again and give them a further tightening.

See remarks on page 35 regarding the fitting of the gasket.

**Grinding the Valves.** In order that the valves shall be gas tight, it is necessary for the bevelled surfaces of the valve and cylinder seat to make perfect contact when fitted together. This is achieved by grinding the two surfaces together, but each valve must be ground into the correct seat as indicated by the numbers stamped on the valves.

A small tin of special grinding paste may be obtained, containing both fine and coarse grades.

The grinding process consists in coating the bevelled face of the valve with grinding paste, a little lubricating oil and refitting the valve in its guide.

A small spring may with advantage be fitted under the valve head for the purpose of lifting the valve from its seating during the grinding operation. Using a valve grinding tool rotate the valve to and fro. After each movement, allow the spring to lift the valve, then press down into another position before giving the next turn. This will keep the grinding even.

Continue these operations until the surfaces assume an even matt appearance, then wipe away all traces of paste from the valve seats; any paste finding its way into the valve guides would do serious harm.

If the valve seats are in fairly good condition it will only be necessary to use the fine paste, but if this is insufficient to produce a clean surface a little coarse paste must be used. When the valves are badly pitted, they should either be renewed or skimmed on special machines which are installed at most garages. Do not attempt to grind them in, or you will remove an undue amount of metal from the cylinder head seats.

Any valve which appears to be distorted must be replaced by a new one; to attempt to grind them in will only damage the valve seating.

After each valve has been ground it must be withdrawn and washed in paraffin, also the valve seatings must be thoroughly cleansed, using a rag moistened with paraffin. The valves can now be reassembled.

In the event of a new valve being fitted, it is most necessary to grind it to its seat.

## ENGINE

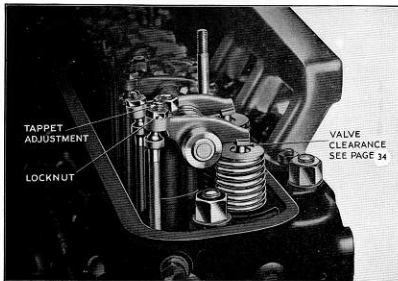

**Tappet Push Rods.** Return springs are now incorporated on the Tappet Push Rods; they are fitted at the lower end of the Rods, inside the crankcase, and are held in position by locating washers.

The Push Rods cannot be withdrawn until the locating washers have been removed.

To obtain access to the springs and washers, remove the side cover complete with the distributor, the springs will then be visible. Compress the springs to remove the locating washers. When the side cover and distributor has been refitted, the ignition should be retimed. See page 39.

**Note.**—It is not necessary to remove the Push Rods when dismantling the engine for decarbonizing, the cylinder head will lift off, leaving the Push Rods in position.

## ENGINE

If the car is taken to a Jaguar Dealer, the mechanics who will do the work will be familiar with the adjustments necessary during a major overhaul, but in case this is not convenient, we give below a brief list of the correct adjustments for the benefit of any mechanic to whom the car is strange.

Precision, thin shell, main and big end bearings are fitted to the engines.

Service Departments are warned that when fitting new bearings the white metal surface must not be scraped or touched in any way, but the bearings must be fitted exactly as supplied. It is further important that neither the ends of the bearing shells nor connecting rod caps should be filed in an attempt to tighten the bearings.

The wear on the crankshaft is very low and, up to high mileages, it will be found that standard-sized bearings can be fitted. With dry journals and bearings a maximum clearance of  $.003''$  can be allowed. Should journals on the crankshaft become worn, the crank must be reground and suitable undersize bearings ordered. Stocks of bearings  $.020''$  and  $.030''$  undersize are maintained at the Factory.

Crankshaft end play in rear bearing .. .. .	0-006"
Connecting rod end play at big end .. .. .	0-004"
Camshaft end play .. .. .	0-006"
Gearbox mainshaft end play .. .. .	0-006"



View inside Crankcase.

## ENGINE

**Valve Timing.** When any part affecting the valve timing is removed, take particular note of the markings on the chain wheel teeth; if these are indistinct, scribe marks on the faces of the wheels before removing the timing chain. This will save the work of retiming the engine when the parts are reassembled, as they can simply be set to the marks.

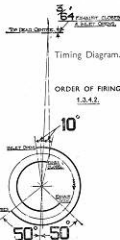

If the marking operation has been neglected, the camshaft can be set to the timing diagram shown. It is only necessary to time one cylinder, as all the cams are integral with the shaft.

When resetting the timing, it may be found that with the wheels in position it is not possible to get the timing accurate, as one tooth movement of the chain gives too great a correction.

In this case, the camshaft wheel, which is driven by two dowels, should be removed and replaced with the other two holes in the wheel on the dowels, which will set the wheel half a tooth out from its original position. If this is still not correct, the wheel may be removed and reversed, which, owing to the manner of drilling, will give a further two positions, making an adjustment to a quarter of a tooth.

When checking the valve timing, the tappets should be set to a clearance of  $.020$  inches—afterwards reset to recommended clearance. See pages 33 and 34.

**Ignition Timing.** The ignition measured on crankshaft advance is mostly automatic and the distributor should be set to fire 10 degrees before T.D.C., with the manual control set at full advance. This may require slight alteration when tested on the road.

Turn the engine until No. 1 inlet valve closes and continue turning until No. 1 piston reaches top dead centre. This position is indicated by a mark on the flywheel, which can be seen through the hole in the top of the clutch housing.

Then slacken the clamp bolt and turn the distributor body until the contact breaker points are just separating when the distributor arm is opposite No. 1 segment in the cover, then retighten the bolt.

**Timing Cover.** Whenever the timing cover is removed it should be replaced in the following manner, to ensure correct oil retention and quiet running.

First replace the timing cover with the securing screws just "holding," then place a drop of oil on the inside of crankshaft pulley and fit pulley on crank, but with the driving key removed. The pulley will not rotate freely if it rubs on the hole in the timing cover, in which case tap the sides of the cover until it is possible to "spin" the pulley, and then tighten the securing screws. If these precautions are not taken, oil leakage at this point will be experienced.

It is advisable to recheck for pulley freedom after tightening the screws, to make sure that the cover has not moved in the process. Finally, fit the pulley key and tighten up the crankshaft nut.

## GEARBOX

The gearbox is built in unit construction with the engine; the box itself is of cast iron, well ribbed for strength. The gearbox, which is of the normal countershaft type, has synchro-mesh for the engagement of the three higher ratios, first and reverse being straight teeth sliding gears. On top, third and second the gears are the double helical type with special overlapping teeth which give high strength factor and ensure complete silence of operation. The main shaft is maintained on roller bearings at either end.

No attention should be necessary to the gearbox except the occasional inspection of the oil level, as indicated in lubrication instructions. This can easily be done by means of the dipstick, which shows through the top of the gearbox housing inside the car.

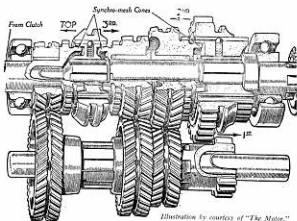
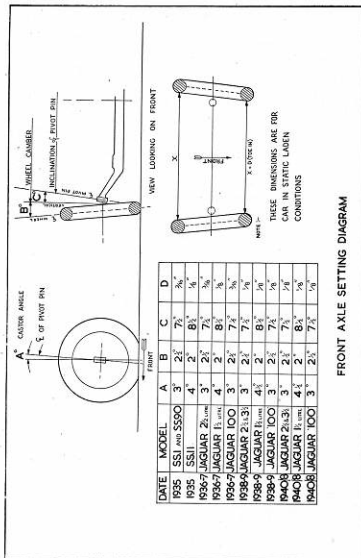

Illustration by courtesy of "The Motor"  
Showing the synchro-mesh cones in action

## FRONT AXLE

The front axle is of the normal beam type with stub axles of the reversed Elliot type, that is, the jaw of the stub axle fits over the end of the boss on the axle beam and is secured by a swivel pin, which is held in position by a tapered cotter.

The particulars of adjustment for bearing and methods of checking the track are given under the heading of steering adjustment. A diagram showing the correct angles of the wheels is given on the opposite page, and this section of the manual should be referred to when making any adjustment.



## STEERING

The steering box is a Burman Douglas type worm and nut. The line drawing on page 43 shows an exploded view of the various parts. With this type of gear, owing to the very large working surfaces, only negligible wear is likely to occur during the life of the car and, normally, no adjustment should be required. With a fast car of this type the steering is, however, such an important feature that occasional attention is warranted. Troubles which can occur and methods of elimination are given overleaf.



## STEERING

**Steering Kick,** wheel flutter or uncertain steering at speed, may be due to a number of causes or possibly, a combination of causes. The symptoms are excessive wheel movement when striking a pothole or similar small obstruction in the road, the wheel tends to kick to one side or the other. Check as below, paragraphs (a), (b), (c), (d), (e), (f) and (g).

**Stiff Steering.** Where the steering appears to be unduly heavy and lacks directional control at low speeds or fails to return properly after a bend, firstly check the tyre pressures, grease swivel pins and steering joint thoroughly with gear oil as recommended, making sure that the oil is getting to all the bearings by observing the oil exuding when the bearings are over-filled. (Not the hubs.)

If, after this, the stiffness still persists, check the steering column adjustment (paragraph f), which may have been taken up too tightly. Check also the line up on the column mounting (paragraph h). If correct adjustment on these lines still fails to ease the steering, a seized swivel pin is possible and the axle will have to be stripped and the bearings examined.

**Heavy Steering.** Where the steering is heavy and yet appears quite free, returning, if anything, too rapidly after a bend, excessive castor angle may be suspected. Firstly, check as instructed in paragraphs (a), (b), (c) and (d). If, however, these fail to effect a cure, the axle must be examined for castor and wheel camber. The correct dimensions are shown in the chart on page 41.

### Steering Adjustments.

- Tyre pressures, too low pressure in one or both front tyres.
- Wheels. See that hub nuts are tight. Check spring clip bolts on axle for tightness. Check all ball pins and steering arm nuts for tightness.
- Front hub bearings. Check slack by jacking-up the front of the car and rocking the wheel; a slight perceptible shake should be present. If this appears excessive, adjust. To do this, jack-up the front axle and remove the road wheels. Remove the split pin from the stub axle nut and screw up the nut until it is felt to be tight, turning the wheel at the same time to allow the rollers in the bearing to assume their correct position, then slack back two slots and fit a new split pin.
- Check toe-in of front wheel. The best method of checking this is by means of the Dunlop Alignment Gauge. This check can be carried out for a small charge at any Dunlop Service Depot, or most of the Main Dealers have a Dunlop or similar equipment with which a check can be made. If, however, this equipment is not available, make a check as follows:

Set the wheels in a straight-ahead position and by means of trammels, take the measurement from the front of one wheel rim to the other in line with the hub cap. Now take a similar measurement at the rear of the wheel rim. This latter measurement should be greater than the front measurement by the amount shown on the chart. If it is found to vary from this figure, slack off the clips on the steering cross tube and adjust the tube until the correct dimension is obtained. The cross tube has right and left-hand threads, so that there is no need to dismantle the ball pins in order to make an adjustment. Turning the tube one way increases the toe-in, and the other way decreases it. If it is found the reason for the adjustment having been lost is a bent cross tube, this tube must be replaced. Be sure to tighten up the nuts carefully at either end of the cross tube. This should be periodically examined, as any slackness at this point will cause the ends of the rod to wear loose on the thread and make it necessary to replace the tube complete if wear is allowed to take place.

(e) Front shock absorbers. Remove and test for resistance. (See Shock Absorbers, page 44). A shock absorber that has completely failed will allow a violent kick to be transmitted to the steering hand wheel, whilst a weakened shock absorber will permit kick to a lesser degree.

(f) Check back lash in steering wheel. With the offside of the bonnet open, have an assistant move the steering to left and right, giving in all about 1" movement on the rim of the wheel. Carefully observe the steering arm at the bottom of the

## STEERING

box, if no movement at all is discernible, the steering column ball race requires adjustment. The movement of the arm is, in any case, small, so that unless the observer is experienced, a particularly close watch should be kept.

(g) To make the adjustment, release the clip on the steering hand wheel and lift to its highest position, two nuts will be found concealed by the volute spring; holding the lower nut, slack off the lock nut, screw down the lower nut till tightness is felt and slack back one-eighth of a turn, afterwards tightening the lock nut.

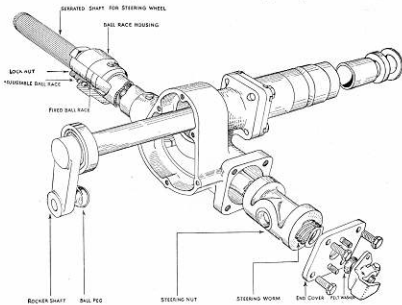

Steering Gear

(h) To check the column mounting, the steering box is fitted with three legs which form the attachment to the frame and are so arranged that true alignment of the steering can be obtained. First, slack off the lock nuts on either side of the single rear foot and turn both nuts clear of the foot (do not loosen the bolt in the frame), now slack the two set pins on the front feet, move the steering wheel slightly from side to side to make sure the steering takes its own position, and retighten; next bring the lock nut on the frame side of the rear bolt out to the foot end, taking care not to move the foot, tighten up the other lock nut. This ensures that the steering has taken its own alignment and there is no distortion on the column or nut.

## CHASSIS SUSPENSION

Both front and rear springs are of special design, the result of extensive experiment, and provide comfortable riding under varying speed and road conditions.

Semi-elliptic laminated springs are fitted, both front and rear. The front spring front eye has a bronze bush and the rear of the front spring is fitted with a sliding trunion, to eliminate any side movement on the spring due to steering thrusts; the side clearance on this trunion box is adjustable by means of shims behind the cover plate, and should be from  $0.04^{\circ}$  to  $0.12^{\circ}$ . The rear springs are equipped with

## CHASSIS SUSPENSION

Silentbloc bushes and require no attention. Fibre washers are fitted at the end of the Silentblocs to reduce, as far as possible, axle side movement and eliminate the chance of squeaks occurring due to Silentbloc movement in the spring eye.

All springs are lead-coated to prevent rust and to give a constant friction value on the spring leaves. It has been found that although the lead coating has the effect of making the springs rather stiff in the initial stages, as soon as the springs are bedded in, the friction value of the lead coating remains constant and, consequently, the ride of the car is not affected by weather or climatic changes. The spraying of the springs with penetrating oil is not recommended, as the effects of this only last a short while, and the shock absorbers are set to allow for the lubricating effect of the lead coating in the dry condition.

The Luvax-Girling Hydraulic Dampers are accurately set before leaving the Works to give the amount of damping most suitable for the car to which they are to be fitted. No further adjustment is required.

Very occasionally, if a uniform resistance is not given through a complete stroke of the lever arm, then it may be necessary to top-up the shock absorber with Luvax Official Piston Type Shock Absorber Thin Fluid. The resistance of the shock absorbers may be checked by bouncing each corner of the car up and down. If it is suspected that the damping of the springs is inadequate, a more positive check can be made by disconnecting the shock absorber connecting link and moving the lever by hand. A uniform resistance throughout the stroke indicates that no attention is required, but if the resistance is erratic and free movement of the lever arm is felt, the shock absorber must be removed from the car for topping up.

Before removing the filler plug, which is located on the side of the body, carefully wipe the exterior of the shock absorber to ensure no dirt or foreign matter enters through the filling hole. Fill up the shock absorber to the bottom of the filler plug hole.

Whilst adding fluid to the shock absorber, move the lever arm up and down, through its complete stroke, so as to expel any air from the pressure chambers.

The Luvax pressure filler, which can be obtained from any Lucas Service Depot or Lucas Agent, provides a convenient means of "topping-up" the shock absorbers.

On no account neglect the operation of "topping-up", because if the low pressure chamber of the unit is allowed to become empty, air will enter the pressure cylinders and the action of the shock absorber will become impaired.

USE ONLY GIRLING OFFICIAL PISTON TYPE SHOCK ABSORBER THIN FLUID. This is a special fluid, the properties of which have been carefully selected to comply with the conditions essential for the efficient working of the shock absorber. It can be obtained from any reputable garage or Lucas—C.A.V.—Rotax Service Depot in one-pint tins with special pouring spout.

## REAR AXLE (HYPOID TYPE)

With the Hypoid type of axle the pinion is slightly offset from the centre line of the crown wheel. The axle is very carefully adjusted and crown wheel and pinion adjustment should require no attention during the life of the car, except for careful adherence to the instructions given in the lubrication section of this manual.

The rear hubs are adjustable by shims behind the backing plates. The desirable end float liable in the axle shafts is .003" to .007". The adjustment at this point should not be frequently necessary, and it is advisable to have this done either at the works or by one of our dealers.

**Propeller Shaft.** If the propeller shaft has been removed, it is essential when reassembling the front end splines to see that the arrows on the universal joint and propeller shaft end are in line. If these are not in line, it is possible that the propeller shaft will not transmit uniform motion.

## REAR AXLE (HYPOID TYPE)

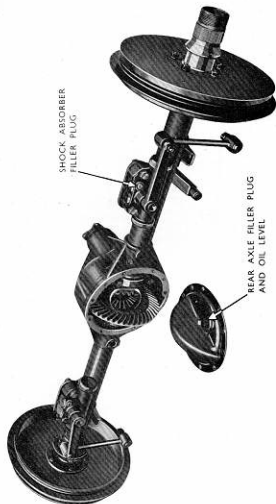

## CLUTCH

The clutch is a Borg & Beck single dry plate type incorporating a torsional damper on the driven member.

The clutch does not require any lubrication, and the friction surfaces must be kept free from oil. No attempt should be made to adjust the clutch itself; provision, however, is made for an adjustment on the pedal control; this adjustment compensates for the wear which may take place on the fabric facings, or the graphite release bearing.

It will be noticed that after a very considerable mileage the free travel of the pedal will gradually be reduced; this free travel should not be allowed to be less than  $\frac{1}{4}$ " measured on the pedal pad. Under no condition must the travel of the pedal be restricted by contacting with the floorboards; this would result in a slipping clutch, causing excessive wear on the fabrics.

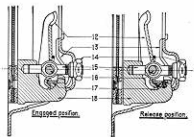
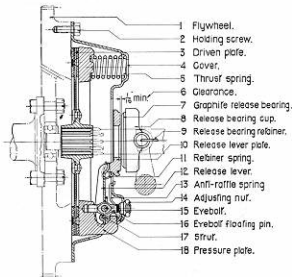

## POSSIBLE TROUBLES AND THEIR REMEDIES

CERTAIN TROUBLES may occur in connection with motoring, and we give an analysis on pages 48 to 49 which will help the owner to correct any fault which may arise.

If the fault cannot be corrected, the owner is strongly advised to take the car to the distributor or dealer from whom the car was purchased. If the car is on tour, it is advisable to take it to the nearest Jaguar Dealer.

It will probably be found that the Dealer who is familiar with the car will quickly be able to rectify any trouble which may occur.

## LOCATION AND CORRECTION OF FAULTS

Make sure of the cause of the trouble before attempting to make any adjustments. If in doubt, do nothing, but carefully—

### Engine will not start.

#### ANALYSE THE FAULT.

1. **Lack of Petrol.** See that the petrol tank contains petrol, depress the carburettor tickler pin and operate priming hand lever on the petrol pump to see if petrol is flowing to the carburettor.

If the petrol pump is at fault, refer to page 26. Make sure that the petrol pipes and filters are not stopped up or air locked.

2. **Sparking Plugs.** These may be dirty, due to long use without cleaning, or the points may be burnt causing the gaps to be too wide. Remove, clean and reset the points, as described on page 33. If there is no spark at the plug, it may be due to a disconnected or broken wire or a fault in the distributor or coil.

3. **Ignition Distributor.** See that the contact breaker points are clean and in correct adjustment (page 33). See also that the contact breaker arm moves freely. If the spark is incorrectly timed, the distributor control lever may have slipped. Reset the ignition as indicated on page 33.

4. **General.** If the starter does not turn the engine over quickly enough due to the accumulators being run down, use the starting handle.

See that there is no air leak in the induction pipe which would cause the mixture to be weak. Use the correct grade of oil in the engine.

A too heavy oil causes stickiness in the working parts, thus putting an overload on the starter. Use recommended oil.

### Engine runs imperfectly.

**Lacks Power.** Make sure that the throttle opens fully when the accelerator is depressed. If black smoke comes from the exhaust the mixture is too rich, probably due to the jet control not being pushed home. See page 8.

If the mixture is too weak, resulting in "spitting back" in the carburettor or explosions in the silencer, there may be a partial stoppage in the petrol system. See remarks on page 25.

The lack of power may be due to overheating caused by driving with a retarded spark or the distributor may have become incorrectly set.

Examine the water and oil levels and see that the oil pressure is correct.

The engine may lack power if the valve clearances are insufficient—these should be reset, as instructed on pages 33 and 34.

Examine the sparking plugs and do not fit the wrong type of plug.

**Engine Fires Irregularly.** If due to faulty sparking plugs, detect by short-circuiting each plug in turn, using a screwdriver or similar tool having an insulated handle. Let the metal tool first make contact with the cylinder metal and then bring it also into contact with the plug terminal. When a plug is found which when "shorted" does not affect the running of the engine, remove and clean this plug and see that the gaps are correctly set. An alternative method is to use a spark tester which shows the intensity of the spark by the intensity of light in the tester.

Examine the porcelain insulation for cracks. If a crack is discovered a new plug will be required.

Lack of compression in any one cylinder may cause uneven running and this may happen if a valve stem becomes sticking or if dirt under the valve seat prevents proper closing with possibly ultimate burn of the valve. The cylinder in which the compression is weak may be found by turning the engine by hand and testing each cylinder separately. If the above items are not at fault, the cause of low compression may be worn piston rings.

Water may reach the distributor or plug terminals when the car is being washed and so cause short-circuiting of the current. Examine the connections and remove the distributor cover to make certain there is no water inside.

## LOCATION AND CORRECTION OF FAULTS

**Engine Knocks.** Check timing. If this has become advanced too far, knocking will result. If however, when retarding to eliminate the knock, the engine loses performance, it is possible that the engine needs decarbonising. The use of an unsuitable plug will often give this effect.

Check water level, an unsuspected leak in the circulation may have caused a loss while running.

**Engine Overheats.** This may occur if there is insufficient oil in the engine or insufficient water in the radiator, or if the ignition has slipped and become too far retarded. It may also be caused by carbon deposit in the combustion chambers or a lime deposit in the radiator. If very hard water has been used in the cooling system, impurities will be deposited on the cooling surfaces and thus require cleaning. Drain out the water and flush with a hose.

**Important.** Do not use any cleaning solution containing washing soda or potash, as these substances would attack the materials used in the construction of the radiator.

**Engine runs erratically.** If by any chance the condenser in the distributor has broken down, the engine will show symptoms similar to both carburettor and ignition troubles. When the carburettor is found to be in order, it is well to examine the distributor points which will be dirty if the condenser is at fault. Clean the points and if they rapidly become dirty again on running, have the condenser examined. See page 33. Make sure that the contact breaker arm is not sticking. The engine will run erratically when the actual wire has broken inside the insulation. This is then a difficult matter to trace.

**Engine stops after a few revs.** May be due to faulty ignition or weak mixture. Also if the mixture is too rich, the engine may stop. If the level in the float chamber is too high due to the needle seating badly, tap lightly.

A high petrol level may be caused by a punctured float, and in this case it will be necessary to empty it and have it resoldered, taking care not to increase its weight.

**Insufficient Oil Pressure.** Check the oil level in the sump. If the oil has been in the engine for too great a mileage it should be renewed. If necessary, remove the engine oil sump and clean the suction filter, at the same time cleaning out the sump. If the above points are in order, the pressure relief valve may need resetting or cleaning if dirt has got under the ball seat. To increase pressure release locknut on the relief valve and tighten adjusting screw. The pressure relief valve will be found on the side of the oil cleaner (see illustration of engine). After a great mileage the oil pressure will become low due to wear in the bearings, particularly the connecting rod big ends. The engine then requires a general overhaul to regain the correct oil pressure.

### Starting Motor Fails to Start Engine.

**Turns Engine Slowly.** The battery may be run down due to leaving the ignition switched on or leaving the car standing with the head lamps on.

The grade of oil in the sump may be too heavy. See page 15.

**Will not move Engine.** May be due to a broken connection between the starter and battery or to a bad contact; see that ignition is switched on.

**Will not Disengage.** Starter spindle is extended at the front of the starter and has a squared end, so that it may be turned with a spanner in a direction opposite to the normal rotation. This will draw the pinion out of mesh.

A cover is fitted over the square end of the spindle, which is secured by two screws.

**Dynamo does not Generate.** See that the dynamo revolves. Tighten belt if necessary. Refer to the Electrical Section, page 28.

**Replacement of Bulbs.** We advise you to replace bulbs after long service before they actually burn out, as very often the filaments sag, making it impossible for them to be focussed correctly. When the bulbs show a cloudy appearance they should be replaced.

## COACHWORK

### CARE OF COACHWORK AND GENERAL INSTRUCTIONS

As we have always enjoyed a reputation for high-class coachwork, we are naturally eager that our cars should retain their perfection and immaculate appearance after they have left our hands. For this reason, and for our customers' satisfaction, we advise all Jaguar owners to ensure that the following instructions are complied with.

**Cellulose.** Have your car washed and polished at least once a week. See that all dirt is removed with a soft sponge and hose pipe. Dry the car thoroughly with a good quality wash leather, apply a small quantity of Jaguar polish to a fine muslin cloth and polish an area about four feet square until the cloth becomes dry. Replenish with polish and repeat the operation in another place, and so on until the whole car has been covered. Finish off with a clean, dry cloth. Replacement tins of polish are obtainable from the Jaguar works or through any of our dealers.

Tar remover can be obtained from the works or from any garage, which is quite harmless to the cellulose. Petrol is a good substitute if used within a short time of the tar being picked up.

**Interior Hide.** The seat upholstery may be cleaned with soap and water, using a sponge and leather. Greasy marks should be removed with a soft cloth soaked in clean petrol.

**Interior Head Lining.** Head lining will be kept in reasonably clean condition if cleaned frequently, using a soft hat brush or a piece of mutton cloth soaked with petrol and applied smartly, but without pressure.

**Carpets.** Carpets may be cleaned with petrol after the usual brushing.

**Cabinet Work.** Cappings and instrument board may be polished in the same manner as cellulose.

**Chrome.** All parts chromium plated on steel should receive attention with Chrome Shine at least once a week.

Chrome cleaning is essential, particularly where there is a foundation of a ferrous metal, i.e., hub caps, etc., in order to prevent an accumulation of red oxide on the chrome surface. The weekly use of Chrome Shine will prevent this rust deposit, but if the accumulation of red oxide is permitted to remain on the surface for a considerable time it will be very injurious to the chrome itself.

**Bonnet Hinges.** The centre and side hinges should be lubricated frequently to prevent rust and creaks.

**Seat Slides.** These require very little attention, but it is advisable to check over the securing bolts and apply a little grease to the runners occasionally, to ensure smooth operation.

**The Coupe Drop Head** can be readily opened, but it is important to do operations in the correct sequence.

The front portion must be dealt with first. The canopy rail attaches the head to the screen, the cant or side rails are locked in position and control the movement of the second head stick.

The rear portion of the head is controlled by the outside knuckle joints.

## COACHWORK

### LOWERING THE HEAD of the Drop-head Coupe

1.—Release side rails (cantrails) by means of thumb catch as shewn in illustration "A." Whilst holding the catch open, strike the cantrail smartly with the palm of the hand. This will free it from the dovetail joint which secures it to the canopy rail. Do not yet push cantrails right back.

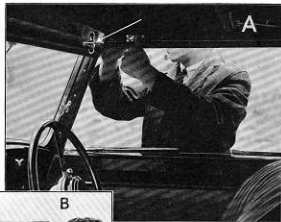

2.—Slacken wing nuts indicated by arrow. Lift front portion (canopy rail) of head from the screen. Roll the fabric round the canopy rail—roll under, not over and place it temporarily on rear portion of head as shewn in illustration "B."

3.—Next, draw the fabric protector sleeves on to the cantrails and secure with press fasteners. Sheaths must be positioned so that press fasteners are to the rear. Now push the cantrails right back, noticing that the nearside rail is in front of the offside rail, and secure with straps as shewn in illustration "C."

Note that the front portion of the head fabric must be rolled as tightly as possible and must lie on top of the curved head stick as shewn in illustration "C." On no account should the fabric be allowed to drop behind the head stick.

4.—Break the outside knuckle joints, lower the head into position shewn in illustration "D" and fit envelope.

**Raising the Head.** To raise the head it is merely necessary to reverse the foregoing operations, the sequence being as follows:

1. Raise rear portion to upright position and tighten outside knuckle joints.
2. Release straps, unroll head and secure canopy rail to top of screen. (See that canopy rail is well down on screen before tightening wing nuts.)
3. Swing cantrails forward and lock into canopy rail. See that the thumb catches lie flush, indicating that rails are properly locked.

## COACHWORK

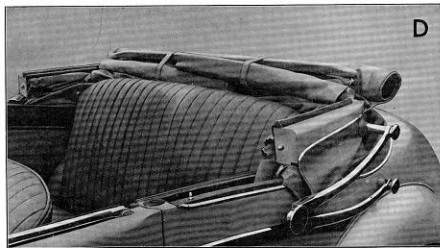
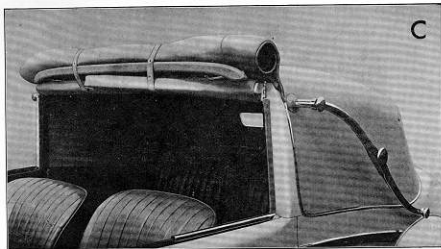

## COACHWORK

**Door Hinges.** These should receive occasional attention with the grease gun to the grease nipples provided.

To preserve the silence of the body work, occasional attention is necessary.

The bonnet-rest, which supports the bonnet on the radiator, should be coated with graphite or anti-squeak compound occasionally.

The wing and bumper bolts should be checked over once in every six months; check over the screws in the seat fittings, and all bolts visible under the bonnet.

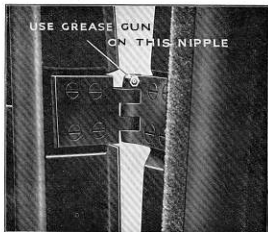

**Door Locks and Buffers.** The bearing surfaces of the lock bolts should receive occasional attention with thin oil. It is essential to ensure the lock bolt is completely home after the door has been closed, as the lock is liable to remain open when the door has been closed carelessly. This can be checked by observing the amount of play or loose movement in the exterior or interior door handles. It is advisable to acquire the habit of testing in this way before the hand is taken away from the door handle.

**Door Light Replacement.** If at any time a door light is accidentally damaged, the nearest Jaguar Dealer will gladly obtain and fit a replacement at current charges, or alternatively, a replacement will be supplied direct from the works. If it is not convenient for the change over to be effected by a coachbuilder, we would advise the owner to simplify the operation by removing the channel from the damaged glass and forwarding this along with the order, so that our works may attach this to the replacement. In the latter case, your order should stipulate which door light is damaged, i.e., near side (passenger), off side (driver). Instructions for replacement are given in correct sequence as follows:

1. Remove the polished fillets from both pillars.
2. Remove garnish rail and capping.
3. Remove door plate, door handle and remote control.

## COACHWORK

4. The garnish rail can now be extracted; wind the window to almost the top position, and bending back the felt glass channel at the rear end it will allow the window to be extracted by drawing the glass toward the rear of the car.
5. When dealing with the front window lights the glass must be extracted by drawing it toward the front of the car.
6. Reverse the operation to fit a new glass.

**Private Door Locks.** Two keys are provided to lock the offside front door (these are the ignition keys), the other three doors are locked from the inside by reversing the opening operation of the handles.

**Interior Door Handles.** The lock and winder handles are secured to the shanks by a pin neatly concealed beneath the spring-loaded bush. To detach a handle, compress the bush and push the pin through with a garnish awl or other suitable instrument.

**Integral Jacking.** At least  $2\frac{1}{2}$ " to 3" of the square portion of the jack must be inserted in the square hole of the jack bracket on the car before commencing to operate the jack.

If for any reason a **central jack or packing** is placed under the front axle, care should be taken not to foul the brake balance lever on axle.

**Spare Wheel and Rear Locker.** For the purpose of giving our customers an adequate amount of covered-in luggage space, the spare wheel has been housed in a separate compartment below the luggage locker.

The spare wheel locker door is combined with the rear number plate and is securely locked by Budget locks in the lower corners; the key for these locks will be found in the tool container in the rear locker lid.

The spare wheel locker lid is held in position by a quadrant arm at each side; to close lid, move the quadrants into their working slots.

The spare wheel is secured to its mounting by a metal strap with a "spring-over" handle; to operate, pull handle, this releases the metal strap allowing the wheel to be withdrawn.



Spare Wheel Housing

A systematised method applied to maintenance and lubrication, compiled to ensure the correct attention to adjustments relative to mileage, as considered necessary to maintain a high level of efficiency throughout the life of the car.

## MILEAGE and MAINTENANCE

The following pages are set out in the form of a diary, showing the speedometer readings, the corresponding key letters, and a space reserved for the signature and address of the operator or agent responsible for the completion of the work required.

We have included the latter section of the diary to serve as a positive record showing that the car has been carefully maintained. The owner will realise that the use of this system will not only maintain efficiency, but will also give a superior second-hand value to the car if produced when exchanging for a new model.

The owner should, whenever possible, have the major operations completed by a Jaguar Dealer.

## MILEAGE AND MAINTENANCE

### A—AFTER THE FIRST 750 MILES (see Service Voucher)

Run the car for three or four miles to warm up the oil, drain the engine sump (if possible, remove and clean), drain gearbox. Use flushing oil for washing out the engine (not paraffin); it is an advantage to wash out the gearbox with flushing oil.

Replenish with the correct oil recommended on page 15.

### B—EVERY 500 MILES

Check accumulator fluid and replenish with distilled water if required.

Apply grease gun to the following nipples and give two or three strokes:—

- 4 nipples on front axle swivel pins.
- 2 front spring shackle pin nipples.
- 1 nipple on fan.
- 1 nipple on water pump (2 strokes only).
- 2 steering track rod nipples.
- 2 steering drag link nipples.

Coat bonnet rest on radiator with a graphite anti-squeak compound.

Apply oil can to bonnet hinges and fasteners, also to door locks (hold the bolt back and insert the oil in the opening exposed around the lock bolt); apply oil to the screen fittings and seat slides.

Apply grease gun to the nipples provided on the door hinges.

### C—EVERY 2,000 TO 3,000 MILES

Drain oil from engine sump, then replenish with fresh oil.

Examine the oil level in gearbox and steering box; fill up if necessary.

Examine the oil level in rear axle; see page 14.

Remove road wheels and apply grease gun to the four hub bearings, giving two or three strokes; if too many strokes are given the grease may find its way into the brake drums and ruin the brake linings. Before replacing the wheels, smear the serrations and bare metal surfaces with grease to prevent rust and facilitate easy removal and replacement.

Check tappet clearances after first 2,000 miles, then every 3,000 miles.

Clean carburettor filter.

"Trafficators." A drop of thin machine oil should be applied by means of a match stick, or feather, to the catch pin between the arm and the operating mechanism. This can be lubricated when the "Trafficator" is switched up.

Lubricate ignition distributor. See page 13.

## MILEAGE AND MAINTENANCE

### D—EVERY 5,000 MILES

Apply grease gun to propeller shaft spline grease nipple.

Check over all engine nuts, also the bolts and screws securing the wings, body and seat fittings, etc.

Check carburettor piston. See page 24.

Remove the sparking plugs, clean and set the points to the gauge supplied with the tool kit. It is advisable when replacing the plugs to inspect the washers and replace with new if necessary.

The engine should now be decarbonised. See pages 34 to 37.

The necessity for decarbonising will be indicated by the falling off in power, heavy petrol consumption, and over-heating. This condition will also produce a metallic tapping, usually referred to as "pinking", and a knocking at slow speeds caused by pre-ignition.

A low grade fuel may cause "pinking"; hence we recommend "ETHYL" brand of fuel, when available.

Further decarbonisation may be necessary every 10,000 miles.

### E—EVERY 10,000 MILES

1. Check resistance of Luvax shock absorbers.
2. Drain back axle and gearbox; wash out with flushing oil.
3. Check brakes:—

Remove the road wheels and then the brake drums. Examine the brake shoe liners, if badly worn, or very greasy, the shoes should be replaced. It is not good practice merely to reline the shoes.

Arrangements are made to supply shoes relined, the worn shoes being returned, for which allowances are made. This procedure is necessary because the linings after being fitted are ground on special machines to ensure accuracy.

After fitting new shoes or when only an examination has been made, adjust brakes as pages 18 to 21. **DO NOT ADJUST BRAKE PULL RODS.** Note all brake rods joint must be perfectly free.

4. **Check Clutch.** The free travel of the clutch pedal should be checked as described on page 46.
5. Drain engine, remove sump and thoroughly clean. Thoroughly wash out with flushing oil, clean oil strainer, check tightness of fan belt.
6. Examine sparking plugs and renew if necessary.
7. Remove road wheels, adjust nuts if any slackness can be felt, check steering connections, take up slack, if any, by renewing the worn parts.





# CONVERSION TABLES FOR THE CONTINENTAL TOURIST

## METRIC INTO ENGLISH MEASURE

- 1 millimetre is approximately  $\frac{1}{32}$ " and is exactly .03937".  
 1 centimetre is approximately  $\frac{1}{25}$ " and is exactly .3937".  
 1 metre is approximately 39", and is exactly 39.37" or 1.0936 yards.  
 1 kilometre is approximately  $\frac{5}{8}$  mile, and is exactly .6213 miles.  
 1 kilogramme is approximately  $2\frac{1}{2}$  lbs., and is exactly 2.205 lbs.  
 1 litre is approximately  $\frac{1}{4}$  pints, and is exactly 1.76 pints.  
 To convert metres to yards, multiply by 70 and divide by 64.  
 To convert metres to miles, multiply by 5 and divide by 8 (approx.).  
 To convert litres to pints, multiply by 88 and divide by 50.  
 To convert kilograms to ounces, multiply by 567 and divide by 20.  
 To find the cubic contents of a motor cylinder, square the diameter (or bore), multiply by 0.7854, and multiply the result by the stroke.  
 1 M.P.G. = 0.3546 kilometres per litre or 3.84 litres per kilometre.

## MILES INTO KILOMETRES

Kilo.	Miles	Kilo.	Miles	Kilo.	Miles	Kilo.	Miles	Kilo.	Miles
1	$\frac{1}{2}$	16	10	31	19 $\frac{1}{2}$	46	28 $\frac{1}{2}$	60	37 $\frac{1}{2}$
2	1 $\frac{1}{2}$	17	10 $\frac{1}{2}$	32	19 $\frac{1}{2}$	47	29 $\frac{1}{2}$	70	43 $\frac{1}{2}$
3	1 $\frac{3}{4}$	18	11 $\frac{1}{2}$	33	20 $\frac{1}{2}$	48	29 $\frac{1}{2}$	80	49 $\frac{1}{2}$
4	2 $\frac{1}{4}$	19	11 $\frac{1}{2}$	34	21 $\frac{1}{2}$	49	30 $\frac{1}{2}$	90	55 $\frac{1}{2}$
5	3 $\frac{1}{4}$	20	12 $\frac{1}{2}$	35	21 $\frac{1}{2}$	50	31 $\frac{1}{2}$	100	62 $\frac{1}{2}$
6	3 $\frac{3}{4}$	21	13	36	22 $\frac{1}{2}$	51	31 $\frac{1}{2}$	200	124 $\frac{1}{2}$
7	4 $\frac{1}{4}$	22	13 $\frac{1}{2}$	37	23	52	32 $\frac{1}{2}$	300	186 $\frac{1}{2}$
8	5	23	14 $\frac{1}{2}$	38	23 $\frac{1}{2}$	53	32 $\frac{1}{2}$	400	248 $\frac{1}{2}$
9	5 $\frac{1}{4}$	24	14 $\frac{1}{2}$	39	24 $\frac{1}{2}$	54	33 $\frac{1}{2}$	500	310 $\frac{1}{2}$
10	6 $\frac{1}{4}$	25	15 $\frac{1}{2}$	40	24 $\frac{1}{2}$	55	34 $\frac{1}{2}$	600	372 $\frac{1}{2}$
11	6 $\frac{3}{4}$	26	16 $\frac{1}{2}$	41	25 $\frac{1}{2}$	56	34 $\frac{1}{2}$	700	435
12	7 $\frac{1}{4}$	27	16 $\frac{1}{2}$	42	26 $\frac{1}{2}$	57	35 $\frac{1}{2}$	800	497 $\frac{1}{2}$
13	8 $\frac{1}{4}$	28	17 $\frac{1}{2}$	43	26 $\frac{1}{2}$	58	36	900	559 $\frac{1}{2}$
14	8 $\frac{3}{4}$	29	18	44	27 $\frac{1}{2}$	59	36 $\frac{1}{2}$	1000	621 $\frac{1}{2}$
15	9 $\frac{1}{4}$	30	18 $\frac{1}{2}$	45	28				

## PINTS AND GALLONS TO LITRES

Pints	Gallons	Litres Approx.	Litres Exact	Pints	Gallons	Litres Approx.	Litres Exact
1	$\frac{1}{2}$	$\frac{1}{2}$	.57	40	5	23	22.75
2	$\frac{1}{2}$	1	1.14	48	6	27	27.30
3	$\frac{1}{2}$	1 $\frac{1}{2}$	1.71	56	7	32	31.85
4	1	2	2.27	64	8	36 $\frac{1}{2}$	36.40
8	1	4 $\frac{1}{2}$	4.54	72	9	41	40.95
16	2	9	9.10	80	10	45 $\frac{1}{2}$	45.50
24	3	13 $\frac{1}{2}$	13.65	88	11	50	50.05
32	4	18	18.20	96	12	54 $\frac{1}{2}$	54.60

# CONVERSION TABLES FOR THE CONTINENTAL TOURIST

## RELATIVE VALUE OF MILLIMETRES AND INCHES

m/m	Inches	m/m	Inches	m/m	Inches	m/m	Inches
1	0.0394	26	1.0236	51	2.0079	76	2.9922
2	0.0787	27	1.0630	52	2.0473	77	3.0315
3	0.1181	28	1.1024	53	2.0866	78	3.0709
4	0.1575	29	1.1417	54	2.1260	79	3.1103
5	0.1968	30	1.1811	55	2.1654	80	3.1496
6	0.2362	31	1.2205	56	2.2047	81	3.1890
7	0.2756	32	1.2598	57	2.2441	82	3.2284
8	0.3150	33	1.2992	58	2.2835	83	3.2677
9	0.3543	34	1.3386	59	2.3228	84	3.3071
10	0.3937	35	1.3780	60	2.3622	85	3.3465
11	0.4331	36	1.4173	61	2.4016	86	3.3859
12	0.4724	37	1.4567	62	2.4410	87	3.4252
13	0.5118	38	1.4961	63	2.4803	88	3.4646
14	0.5512	39	1.5354	64	2.5197	89	3.5040
15	0.5906	40	1.5748	65	2.5591	90	3.5433
16	0.6299	41	1.6142	66	2.5984	91	3.5827
17	0.6693	42	1.6536	67	2.6378	92	3.6221
18	0.7087	43	1.6929	68	2.6772	93	3.6614
19	0.7480	44	1.7323	69	2.7166	94	3.7008
20	0.7874	45	1.7717	70	2.7559	95	3.7402
21	0.8268	46	1.8110	71	2.7953	96	3.7796
22	0.8661	47	1.8504	72	2.8347	97	3.8189
23	0.9055	48	1.8898	73	2.8740	98	3.8583
24	0.9449	49	1.9291	74	2.9134	99	3.8977
25	0.9843	50	1.9685	75	2.9528	100	3.9370

## RELATIVE VALUE OF INCHES AND MILLIMETRES

Inches	0	$\frac{1}{16}$	$\frac{1}{8}$	$\frac{3}{16}$	$\frac{1}{2}$	$\frac{5}{8}$	1	1 $\frac{1}{8}$
0	0.0	1.6	3.2	4.8	6.4	7.9	9.5	11.1
1	25.4	27.0	28.6	30.2	31.7	33.3	34.9	36.5
2	50.8	52.4	54.0	55.6	57.1	58.7	60.3	61.9
3	76.2	77.8	79.4	81.0	82.5	84.1	85.7	87.3
4	101.6	103.2	104.8	106.4	108.0	109.5	111.1	112.7
5	127.0	128.6	130.2	131.8	133.4	134.9	136.5	138.1
6	152.4	154.0	155.6	157.2	158.8	160.3	161.9	163.5

Inches	$\frac{1}{16}$	$\frac{1}{8}$	$\frac{3}{16}$	$\frac{1}{2}$	$\frac{5}{8}$	1	1 $\frac{1}{8}$
0	1.27	14.3	15.9	17.5	19.1	20.6	22.2
1	2.54	31.7	41.3	42.9	44.4	46.0	47.6
2	6.35	65.1	66.7	68.3	69.8	71.4	73.0
3	8.89	90.5	92.1	93.7	95.2	96.8	98.4
4	11.43	115.9	117.5	119.1	120.7	122.2	123.8
5	13.97	141.3	142.9	144.5	146.1	147.6	149.2
6	16.51	166.7	168.3	169.9	171.5	173.0	174.6

Aberedeen	408	491	462	648	612	540	493	456	448	405	271	222	432	386	188	188	609	340	337	503	644	312	276	516	311	345	Aberdeen			
Birmingham	408	85	99	101	171	39	181	381	516	524	34	224	458	619	1027	39	86	110	82	260	558	27	125	179	121	193	Birmingham			
Bristol	491	85	139	96	93	275	194	809	70	364	34	244	518	206	190	118	170	176	119	132	287	477	243	640	48	222	202	Bristol		
Cambridge	462	99	139	—	172	84	96	124	448	209	367	40	219	518	179	144	64	87	53	132	228	82	337	172	116	311	140	Cambridge		
Cardiff	499	101	96	172	—	102	41	232	277	166	382	57	240	332	209	205	122	184	154	160	168	204	104	270	268	174	152	234	Cardiff	
Coventry	418	171	224	84	102	—	43	164	330	171	304	58	333	469	129	117	24	86	102	91	95	100	31	287	172	79	115	165	131	Coventry
Derby	385	179	125	96	41	43	—	198	373	205	274	91	32	430	114	69	58	82	127	42	165	101	319	34	158	163	80	Derby		
Dorset	580	181	194	124	232	164	198	—	488	235	467	172	295	624	107	263	174	205	274	71	239	343	115	202	216	457	389	233	Dorset	
Edinburgh	408	100	100	100	100	100	100	100	100	100	100	100	100	100	100	100	100	100	100	100	100	100	100	100	100	100	100	100	Edinburgh	
Exeter	440	140	140	140	140	140	140	140	140	140	140	140	140	140	140	140	140	140	140	140	140	140	140	140	140	140	140	140	Exeter	
Gloucester	442	244	244	242	304	324	467	440	—	335	352	162	160	209	326	272	212	294	210	152	340	235	235	412	409	464	274	239	Gloucester	
Hull	248	44	124	129	140	151	92	270	236	350	251	190	—	482	221	58	24	100	124	109	100	121	175	417	43	443	220	168	36	Hull
Leicester	403	459	518	313	469	310	634	136	194	67	493	321	—	312	365	467	343	300	353	380	246	511	317	317	413	384	371	345	Leicester	
Liverpool	271	119	206	179	209	226	114	207	62	282	160	161	121	—	67	138	139	53	236	35	104	184	139	136	90	248	273	85	Liverpool	
Leeds	372	107	105	144	104	117	69	262	208	256	209	163	18	365	67	—	89	68	72	192	46	86	69	389	45	40	229	199	22	Leeds
London	412	39	118	64	324	24	174	315	230	308	78	24	657	138	90	—	53	119	98	84	184	64	317	145	60	132	139	108	London	
Luton	188	88	170	86	184	86	55	205	264	260	277	146	76	442	39	48	32	—	110	134	92	144	126	109	44	175	125	46	Luton	
Manchester	408	178	177	154	103	153	174	309	222	212	124	180	133	72	119	110	—	101	135	149	226	139	72	232	238	104	190	192	Manchester	
Newcastle	408	152	152	148	95	83	329	209	210	310	310	200	120	—	355	236	192	88	30	100	188	270	352	228	163	276	135	199	Newcastle	
Newcastle-on-Tyne	232	198	282	228	302	302	165	345	220	150	232	240	321	246	104	86	144	—	143	123	140	254	680	105	166	208	389	80	Newcastle-on-Tyne	
Oxford	407	62	82	504	101	124	393	134	660	50	175	321	184	126	149	53	148	254	—	443	232	144	143	140	172	248	172	Oxford		
Penzance	644	260	174	330	267	319	351	532	104	532	220	419	712	319	189	312	372	326	378	332	480	245	—	143	230	221	400	172	Penzance	
Scarborough	312	158	433	172	248	243	311	200	348	233	210	43	337	236	65	45	107	140	108	122	443	—	94	203	210	41	Scarborough			
Sheffield	370	72	160	116	176	79	36	234	236	242	242	20	64	413	90	30	40	42	164	36	116	24	130	94	—	195	188	46	Sheffield	
Southampton	516	175	48	151	152	115	158	460	457	1000	419	112	30	584	248	229	132	175	223	76	203	289	64	221	193	—	102	273	Southampton	
Yarmouth	511	179	122	80	154	165	163	206	389	301	404	213	68	371	273	199	125	238	335	202	247	40	408	210	188	—	192	408	Yarmouth	
York	445	111	302	140	224	311	88	209	323	229	168	36	346	85	22	128	68	104	199	90	80	172	378	41	46	232	192	—	York	

## SERVICE

ADDRESS YOUR ENQUIRIES TO  
SERVICE DEPOT  
JAGUAR CARS LTD.  
COVENTRY  
TELEPHONE NO. COVENTRY 62677 (P.B.X.)

Where your requirements will receive the most careful consideration.

Your Car has a distinguishing number stamped on a plate on the off side of the dummy dash giving engine and chassis number. Both these numbers should be quoted when Spares are ordered, and as a further check, horse power and year of manufacture should also be given.

Should your car give trouble see the Dealer. If you are on tour apply to the nearest Jaguar Dealer.

## LONDON SERVICE DEPARTMENT

Owners in or near London are advised that a special Jaguar Service Department is maintained by Messrs. Henlys Ltd., sole London Distributors for Jaguar Cars. This service department is fully equipped to deal with every kind of repair and overhaul—an expert staff of trained mechanics being retained solely for Jaguar service work. Enquiries should be addressed to:—

## HENLYS LTD.,

Jaguar Service Department,  
Great West Road, BRENTFORD, Middlesex  
TELEPHONE NO. EALING 3477

Should the owner obtain the instruction book without having first obtained a guarantee form, he should apply to the Dealer, who will supply the necessary form. When this is obtained, fill in the bottom paragraph and send the whole document to the Guarantee Department as soon after purchase of car as possible. Guarantee claims are not accepted by our service department unless the completed guarantee forms are in their possession.

## ACCESSORIES AND EQUIPMENT

Proprietary equipment as fitted to Jaguar Cars can either be obtained direct from the manufacturers, whose addresses are given below, or will be supplied by the Spares Department, Jaguar Cars Ltd., at list prices current from time to time.

All Claims for replacement or alleged defective parts must be referred direct to the respective manufacturers to be dealt with under the terms of their guarantee.

Component.	Manufacturers.
Lighting, Ignition and Starting Equipment .. .. .	Joseph Lucas, Ltd., Great King St., Birmingham.
Windscreen Wiper .. .. .	Joseph Lucas, Ltd., Great King St., Birmingham.
Trafficators .. .. .	Joseph Lucas, Ltd., Great King St., Birmingham.
Electric Horn .. .. .	Joseph Lucas, Ltd., Great King St., Birmingham.
Shock Absorbers .. .. .	Girling Ltd., Kings Rd., Tyseley, Birmingham II. Girling Ltd., Luvax Works, Stanley Gardens, Acton, London, W.3.
Speedometer .. .. .	Smith's Motor Accessories Ltd., Cricklewood Works, London, N.W.2.
Rev. Counter .. .. .	Smith's Motor Accessories Ltd., Cricklewood Works, London, N.W.2.
Carburettors .. .. .	Messrs. S.U. Co., East Works, Bordesley Green, Adderley Park, Birmingham.
Tyres .. .. .	Dunlop Rubber Co., Ltd., Fort Dunlop, Erdington, Birmingham.
Road Wheels .. .. .	Dunlop Rim and Wheel Co., Ltd., Holbrook Lane, Coventry.
Oil Pressure and Water Temperature Gauge .. .. .	Smith's Motor Accessories Ltd., Cricklewood Works, London, N.W.2.
Petrol Gauge, Cigar Lighter .. .. .	Smith's Motor Accessories Ltd., Cricklewood Works, London, N.W.2.
Clock .. .. .	Smith's Motor Accessories Ltd., Cricklewood Works, London, N.W.2.
Petrol Pump .. .. .	A. C. Sphinx, Dunstable.
Air Conditioning Unit .. .. .	Clayton Dewandre, Lincoln.

Proprietary articles which are considered to be defective returned to our works will be forwarded to the component manufacturer concerned. Should immediate replacement be required the parts will be charged for, but will be credited if the component manufacturer accepts responsibility under the terms of guarantee. Should responsibility not be accepted, the component manufacturer's reasons for non-supply under guarantee will be submitted.