

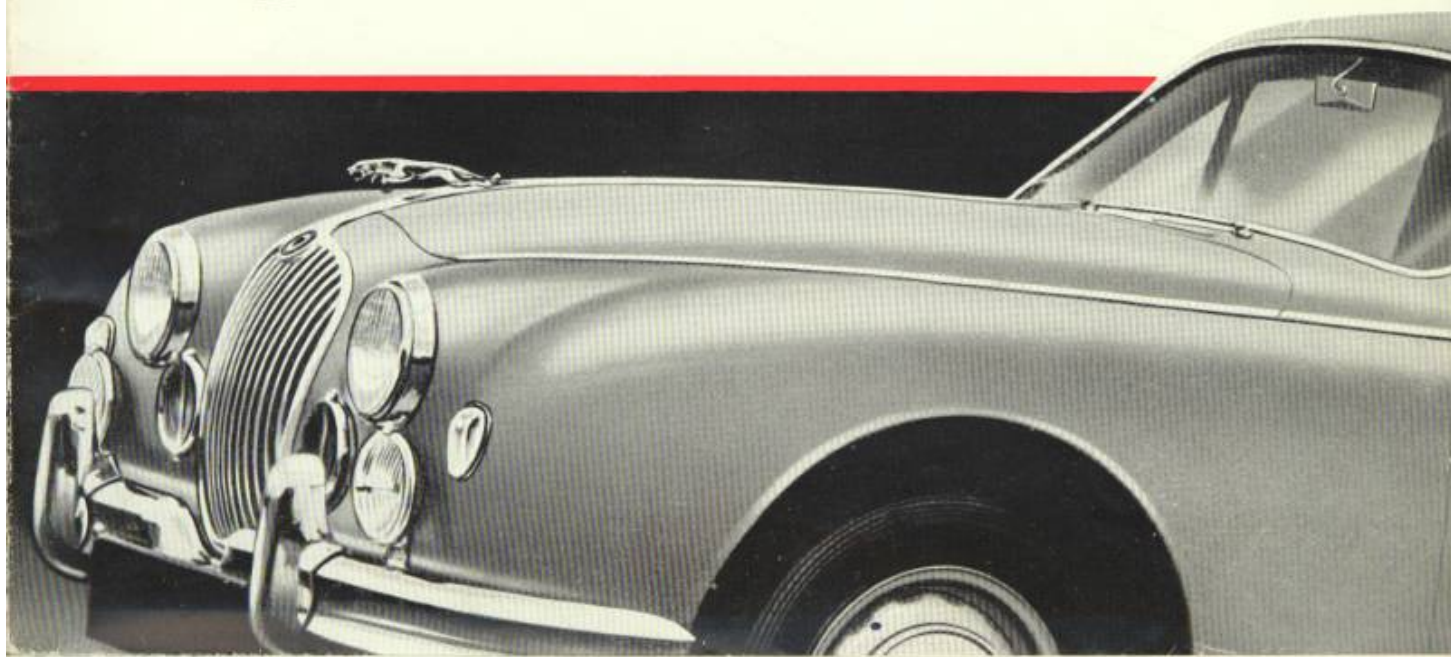

THE JAGUAR

2.4 and 3.4

LITRE SALOONS



The luggage compartment is of extremely generous dimensions having a capacity of 13.5 cubic feet on both models. An interior light is provided to facilitate the handling of luggage at night. The floor is covered with thick felt-backed Vynide for the protection of baggage.

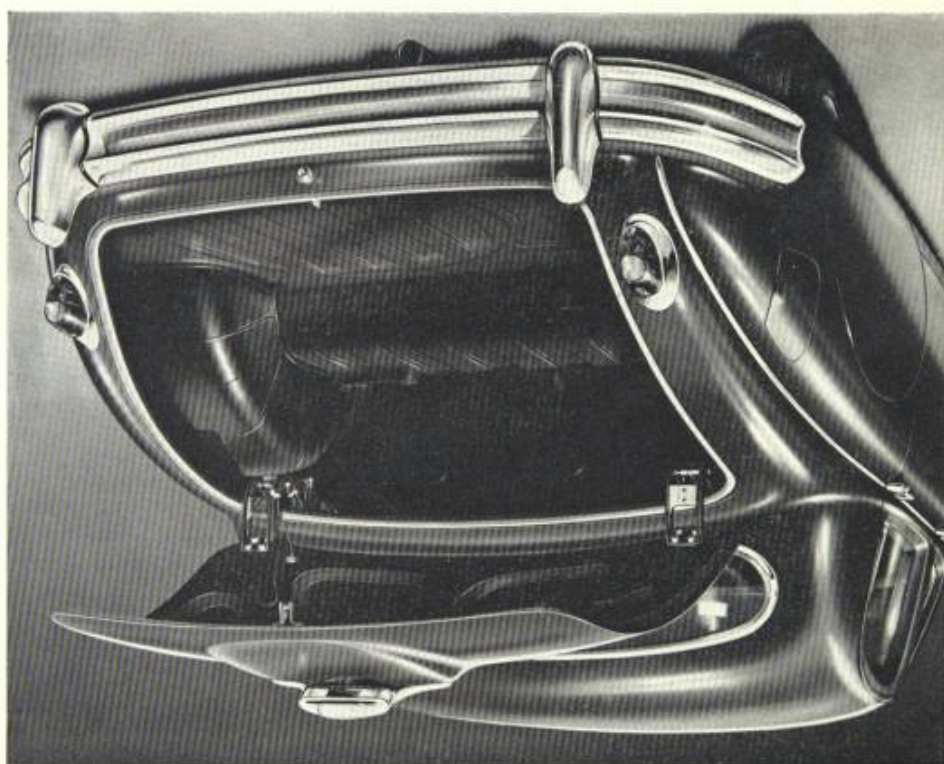

Whether personal preference more powerful 3.4-litre the same cars. Either model of performance allied to the highest order. available with disc brakes overdrive or automatic transmission as optional items

IN THE TRUE JA

Grace... Sp

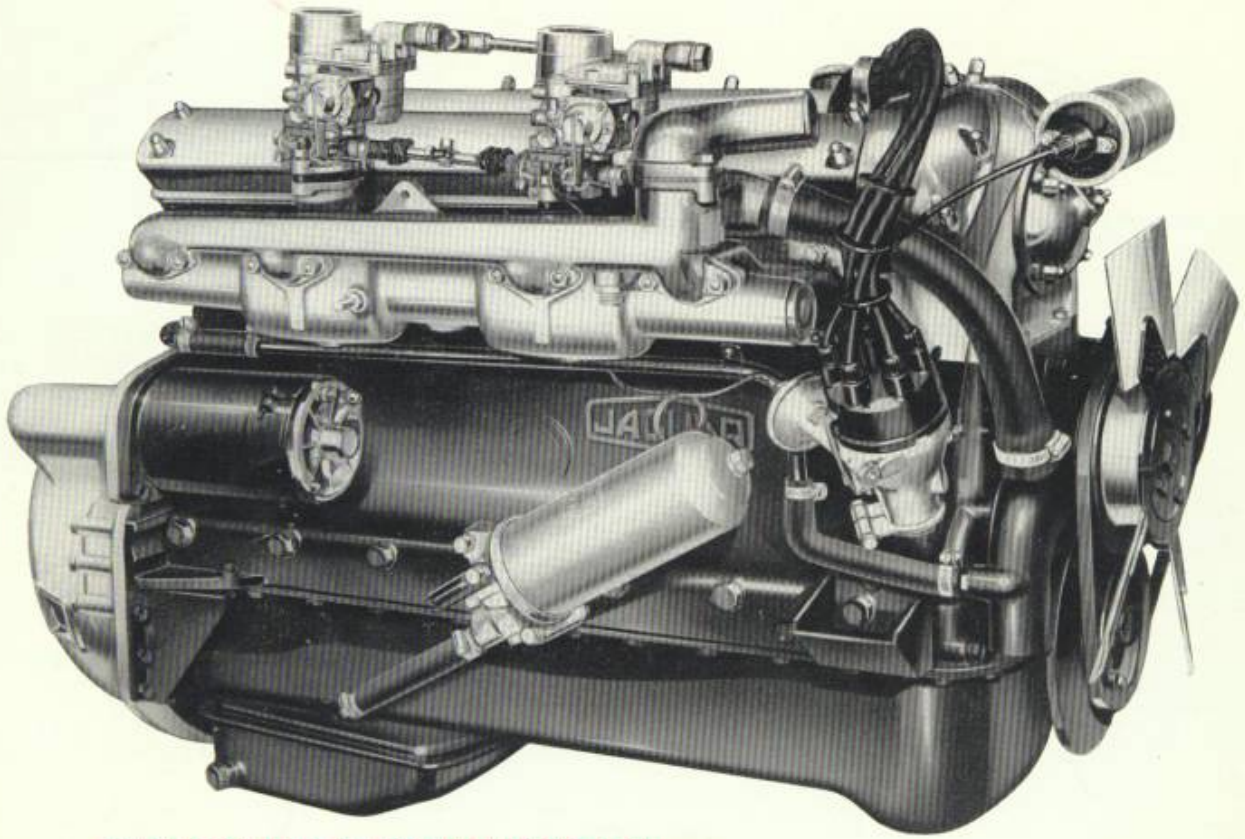

THE SIX-CYLINDER 2.4 LITRE JAGUAR XK ENGINE

(For full details of this and the 3.4 litre engine see overleaf)

Jaguar Cars Ltd. reserve the right to alter specifications at any time without notice.

Printed in England

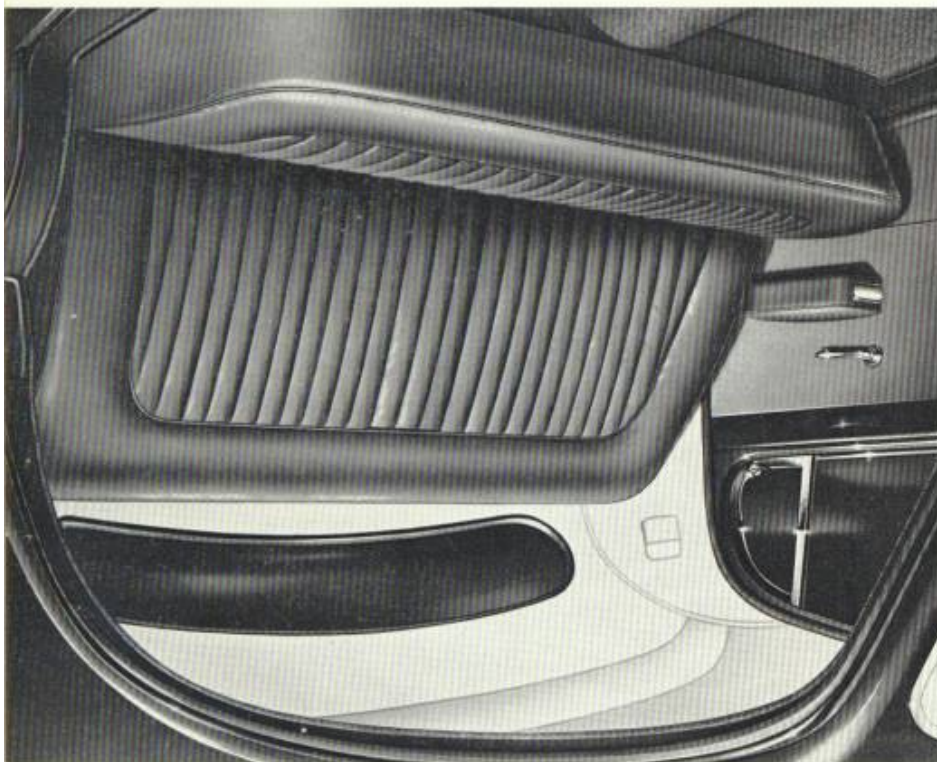

The spacious and luxuriously appointed rear compartments are of identical dimensions on both models and permit of three passengers being carried with ease and in complete comfort. Seating is of finest Vannol real leather over Dunlopillo.

...be for the 2.4-litre or the Jaguar characteristics exist in both offers impeccable road comfort and refinement of Both models are as an optional extra, and transmission are also offered of extra equipment.

JAGUAR TRADITION

Space... face...

THE

2.4

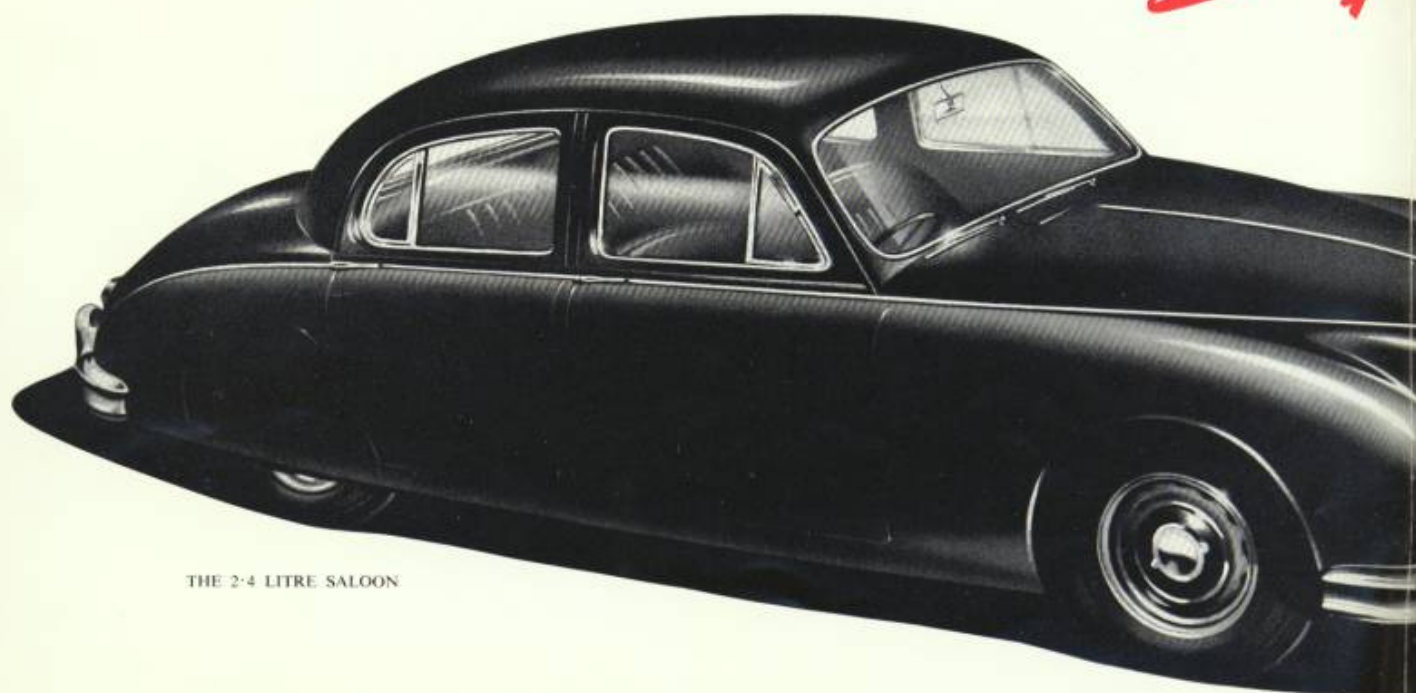

THE 2.4 LITRE SALOON

The 2.4 litre saloon

GENERAL SPE

ENGINE. Six cylinder 2.4 litre Jaguar XK engine. 70° twin overhead camshafts driven by a two-stage roller chain. 83 mm. bore × 76.5 mm. stroke, capacity 2,483 c.c. developing 112 h.p. at 5,750 r.p.m. Compression ratio 8 or 7 : 1 (optional). Twin Solex down-draught carburetters. Cooling by pump and fan with by-pass thermostat control. Forced lubrication throughout by submerged pump system incorporating a full flow filter. Chrome iron cylinder block. Cylinder head of high tensile aluminium alloy with hemispherical combustion chambers. Aluminium alloy pistons. Steel connecting rods. 2½ ins. diameter counterweighted crankshaft carried in seven large bearings.

TRANSMISSION. (Manually Operated Gearbox.) Four-speed single helical synchromesh gearbox. Gear change lever on floor between front seats. Gear ratios: 1st and Rev. 14.41, 2nd 7.94, 3rd 5.48, 4th 4.27. Borg and Beck 9 in. single dry plate clutch with hydraulic operation. Hardy Spicer propeller shaft. Hypoid rear axle.

TRANSMISSION. (Overdrive Model.) As above, with addition of a Laycock de Normanville Overdrive controlled by a switch mounted on the screen rail. Gear ratios: 1st and Rev. 15.36, 2nd 8.46, 3rd 5.84, 4th 4.55, Overdrive 3.54.

TRANSMISSION. (Automatic Transmission Model.) Borg Warner Automatic Transmission with driver controlled intermediate gear hold. Gear ratios: low, 21.2-9.86; intermediate: 13.2-6.14; direct top, 4.27.

SUSPENSION. Independent front suspension incorporating semi-trailing wishbones and coil springs with telescopic shock absorbers. Trailing link rear suspension by cantilever semi-elliptic springs, radius arms and telescopic shock absorbers.

BRAKES. Lockheed "Brakemaster" servo assisted self-adjusting hydraulic brakes. Brake drum diameter 11¼ in. Friction lining area 157 sq. in. Dunlop disc brakes on all four wheels as optional extra. "Pull up" handbrake mounted at floor level.

STEERING. Burman re-circulating ball type steering with 17 in. diameter adjustable steering wheel. Left- or right-hand steering optional; 3½ turns from lock to lock. Turning circle 33½ ft.

WHEELS AND TYRES. Pressed steel bolt-on disc wheels fitted with Dunlop 6.40 × 15 in. low pressure tyres. Wire spoke wheels available as an optional extra on the disc brake models only. Spare wheel and tyre.

FUEL SUPPLY. By S.U. electric pump. 12 Imperial gallon capacity.

ELECTRICAL EQUIPMENT AND INSTRUMENTS. Lucas 12-volt battery, 51 amp/hour at 10 hour rate with current voltage control. Ventilated dynamo. Flush fitting sidelamps, headlamps with dipper control, integral stop/tail lamps with built-in reflector, reversing lamp, self-cancelling flashing direction indicators with warning light, instrument panel lights, twin blended note horns, twin blade two-speed self-parking windscreen wipers, starter motor, vacuum and centrifugal automatic ignition advance, oil coil ignition, 5 in. diameter speedometer, ammeter, oil pressure gauge, water temperature gauge, fuel gauge with warning light.

BODY. All steel full five-seater saloon. Integral body-chassis construction providing maximum rigidity with minimum weight. Four doors. Seats upholstered in finest quality leather over deep foam rubber cushions. Front bucket seats adjustable for height and reach. (Automatic Transmission model has split bench type seat individually adjustable for reach.) Polished walnut instrument panel and interior garnishings. Two glove compartments, one of which is fitted with a lockable lid. Ashtrays. Interior sun visors. Deep pile carpets over thick felt underlay. Heavy duty wrap-around bumpers with overriders.

LUGGAGE ACCOMMODATION. Ample luggage accommodation is provided in a capacious rear locker fitted with an automatic light. 13½ cubic feet of luggage space available.

SPARE WHEEL AND TOOLS. The spare wheel is carried beneath the boot floor in a separate compartment and is readily accessible. The tools, in a special fitted and lined container, are housed in the spare wheel compartment, together with the jack and wheelbrace (or wheel hammer on wire wheel models).

JACKING. Exterior jacking posts, front and rear, enable the car to be lifted with the minimum of effort by means of the jack provided.

PRINCIPAL DIMENSIONS. Wheelbase 8 ft. 11½ in. Track front 4 ft. 6½ in. Track rear 4 ft. 2½ in. Overall length 15 ft. 0½ in., overall width 5 ft. 6½ in., overall height 4 ft. 9½ in. Ground clearance 7 in. Turning circle 33 ft. 6 in. Dry weight 26 cwt. approx.

SPECIAL EQUIPMENT MODEL. The 2.4 litre special equipment model carries: mascot, interior heater and windscreen demisters, centre armrest in rear compartment, windscreen washers, twin foglamps, door-operated interior lights, revolution counter with electric clock, cigar lighter, vitreous enamelled exhaust manifolds.

2 AND 3.4 LITRE JAGUARS

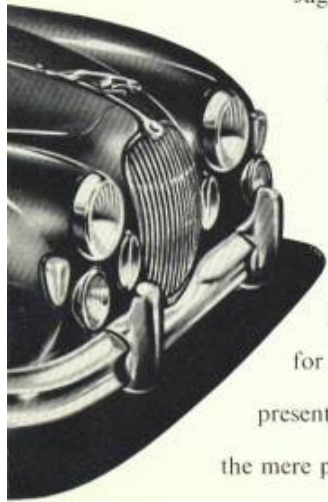

In the 2.4 litre and 3.4 litre Jaguar saloons will be found the embodiment of all the highly specialized technical knowledge and engineering achievement that have gained for the name Jaguar the highest international repute. Their character and breeding are derived from every reward of Jaguar endeavour, every phase of Jaguar achievement and every lesson learned in the hard school of international racing. In outward appearance, the unmistakable Jaguar line of grace is seen with lesser, more compact overall dimensions than those of the Mark VIII and Mark IX, yet the interior has been so skilfully planned that full accommodation for five persons is provided and further provision made for generous luggage accommodation. To those motorists whose desire for a car of compact dimensions is a matter of personal preference the opportunity is at last presented, not only for satisfying that desire, but for gratifying a natural wish to own a car the mere possession of which indicates insistence on owning nothing but the best . . . a Jaguar.

SPECIFICATIONS

The 3.4 litre saloon

ENGINE. Special 6 cylinder 3.4 litre "blue top" XK engine with "B" type head. High lift cams. Twin S.U. type H.D.6 carburettors and double exhaust system, 83 mm, bore x 106 mm. stroke. Cubic capacity 3,442 c.c. (210 cu. ins.). Compression ratio 8 to 1 (7 to 1 optional). Develops 210 b.h.p. at 5,500 r.p.m. 70° twin overhead camshafts driven by two-stage roller chain. Cooling by pump and fan with by-pass thermostat control. Forced lubrication by submerged pump system incorporating full-flow filter. Chrome iron cylinder block. Cylinder head of high tensile aluminium alloy with hemispherical combustion chambers. Aluminium alloy pistons. Steel connecting rods. 2½ in. diameter counter-weighted crankshaft carried in seven large bearings.

TRANSMISSION. (Manually operated gearbox.) Four speed single helical synchromesh gearbox. Gear change lever on floor between front seats. Gear ratios: 1st and reverse, 11.95, 2nd 6.58, 3rd 4.54, 4th 3.54, Borg and Beck 10 in. single dry-plate clutch with hydraulic operation. Hardy Spicer propeller shaft. Hypoid rear axle.

TRANSMISSION. (Overdrive Model.) As above, with addition of a Laycock de Normanville Overdrive controlled by a switch mounted on the screen rail. Gear ratios: 1st and reverse 12.73, 2nd 7.01, 3rd 4.83, Top 3.77, Overdrive 2.93.

TRANSMISSION. (Automatic Transmission Model.) Borg Warner Automatic Transmission system with driver controlled Intermediate gear hold. Gear ratios: Low 17.6-8.16, intermediate 10.95-5.08, Direct top 3.54.

SUSPENSION. Independent front suspension incorporating semi-trailing wishbones and coil springs with telescopic shock absorbers. Trailing link rear suspension by cantilever semi-elliptic leaf springs, radius arms and telescopic shock absorbers.

BRAKES. Lockheed "Brakemaster" servo-assisted self-adjusting hydraulic brakes. Brake drum diameter 11½ in. Friction lining area 157 sq. ins. Dunlop disc brakes on all four wheels as optional extra. "Pull-up" handbrake mounted at floor level.

STEERING. Burman re-circulating ball-type steering with 17-in. diameter adjustable steering wheel. Left- or right-hand steering optional; 3½ turns from lock to lock. Turning circle 33½ ft.

WHEELS AND TYRES. Pressed steel bolt-on disc wheels fitted with Dunlop 6.40 x 15 in. "Road Speed" tyres. Wire spoke wheels available as an optional extra on disc brake models only. Spare wheel and tyre.

FUEL SUPPLY. By S.U. electric pump. 12 Imperial gallons tank capacity.

ELECTRICAL EQUIPMENT AND INSTRUMENTS. Lucas 12-volt battery, 51 amp/hour at 10-hour rate with current voltage control. Ventilated dynamo, flush fitting side lamps, headlamps with dipper control, twin fog lamps, integral stop/tail lamps with built-in reflectors, reversing lamp, self-cancelling flashing direction indicators with warning light, instrument panel lights interior courtesy lights, cigar lighter, twin-blended note horns, twin blade two-speed self-parking windscreen wipers, starter motor, vacuum and centrifugal automatic ignition advance, oil coil ignition, 5 in. diameter speedometer, 5 in. diameter revolution counter with electric clock, ammeter, oil pressure gauge, water temperature gauge, fuel gauge with warning light.

BODY. All steel full 5-seater saloon. Integral body chassis construction providing maximum rigidity with minimum weight. Four doors. Seats upholstered in finest quality leather over deep foam rubber cushions. Front bucket seats adjustable for height and reach. (Automatic Transmission model has split bench-type seat adjustable for reach.) Polished walnut instrument panel and interior garnishings. Two glove compartments one of which is fitted with a lockable lid. Ashtrays. Interior sun visors. Armrests to all doors and central folding armrest in rear. Deep pile carpets over thick felt underlay. Interior heater and windscreen demisters. Windscreen washers. Heavy duty wrap-around bumpers with overriders.

LUGGAGE ACCOMMODATION. Ample luggage accommodation is provided in a capacious rear locker fitted with an automatic light. 13½ cubic feet of luggage space available.

SPARE WHEEL AND TOOLS. The spare wheel is carried beneath the boot floor in a separate compartment and is readily accessible. The tools, in a special fitted and lined container, are housed in the spare wheel compartment, together with the jack and wheelbrace (or wheel hammer on wire wheel models).

JACKING. Exterior jacking posts, front and rear, enable the car to be lifted with the minimum of effort by means of the jack provided.

PRINCIPAL DIMENSIONS. Wheelbase, 8 ft. 11½ in., track front 4 ft. 6½ in., track rear, 4 ft. 2½ in., overall length 15 ft. 0½ in., overall width, 5 ft. 6½ in., overall height 4 ft. 9½ in., ground clearance 7 in., turning circle 33 ft. 6 in., dry weight, 27 cwt. approx.