

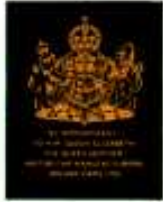

The  
Jaguar  
420G



# The Jaguar 420 G

is a most spacious five seater saloon with a comprehensive specification which offers luxurious comfort, lavish appointments, superbly smooth power and consummate safety assured by splendid acceleration, perfect roadholding and positive stopping

power. A three carburetter version of the 4.2 litre, six cylinder 'XK' engine provides the flexibility of top gear performance for safe rapid overtaking or smooth silent motorway cruising. Fully independent suspension and wide section SP41 tyres

provide outstanding ride comfort and supremely safe cornering. Servo-assisted disc brakes on all four wheels provide effortless, powerful and safe braking . . . in short, Jaguar engineering ensures a degree of perfection unsurpassed in modern motoring.

**for the utmost in high performance prestige motoring ...**





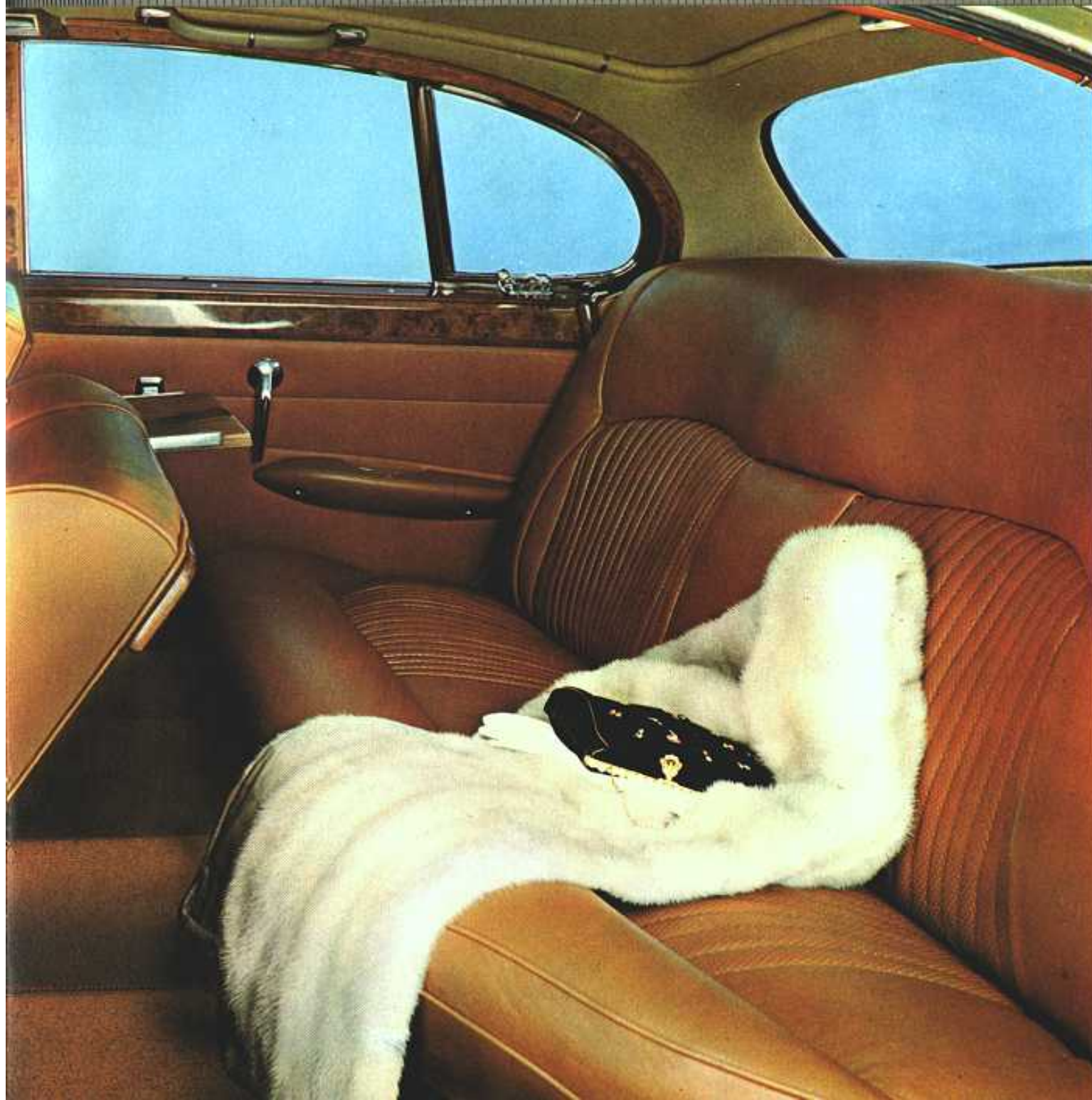

The magnificent Jaguar 420 G provides luxurious accommodation for five people and, with its effortless speed, silence and superb riding qualities, offers a standard of travel akin to that of a modern jet aircraft. Seats richly upholstered in finest quality ventilated leather hide, floors with fitted deep pile carpets over thick felt underlay, central folding armrests, fold-away picnic tables and vanity mirrors, a fresh air heating system with separate controls for each side of the car regulating temperature and direction of air flow and with separate ducting to the rear compartment, all are part of the comprehensive specification listed in the back of this brochure, a study of which reveals the full extent of 420 G refinements for the comfort of driver and passengers alike.

The vast luggage boot of 27 cubic feet capacity accommodates with ease the luggage of five people. An interior light is operated automatically by opening the boot lid. A special container for the comprehensive tool kit fits neatly behind the spare wheel which, like the boot, is fully trimmed to protect the luggage.

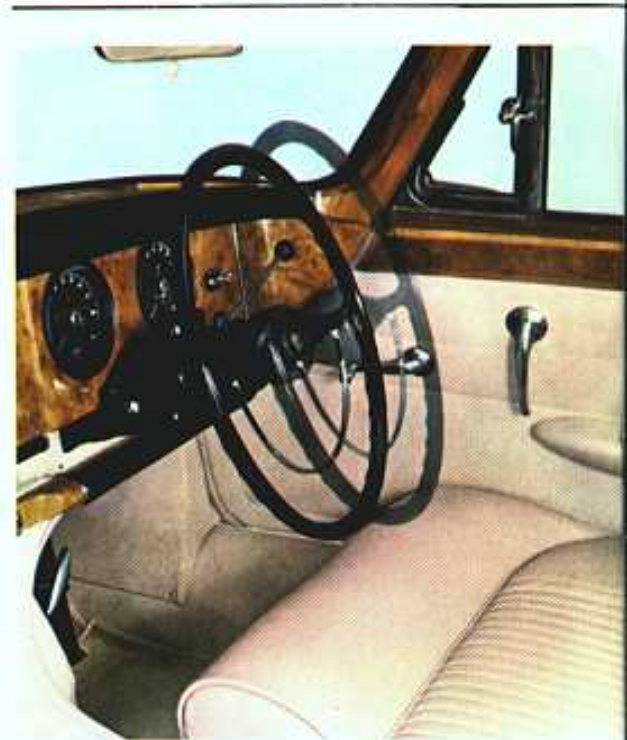



The variable height and reach of the reclinable front seats, together with the telescopically adjustable steering column, enable every driver to select the most comfortable driving position. Separate ducting carries fresh air heating to the rear compartment for which there is a separate ON/OFF switch. The instrument panel, door cappings and window surrounds are in beautifully matched polished walnut which completes the splendour of the 420 G interior. Details of the comprehensive instrumentation are given in the specification in the back of this brochure.



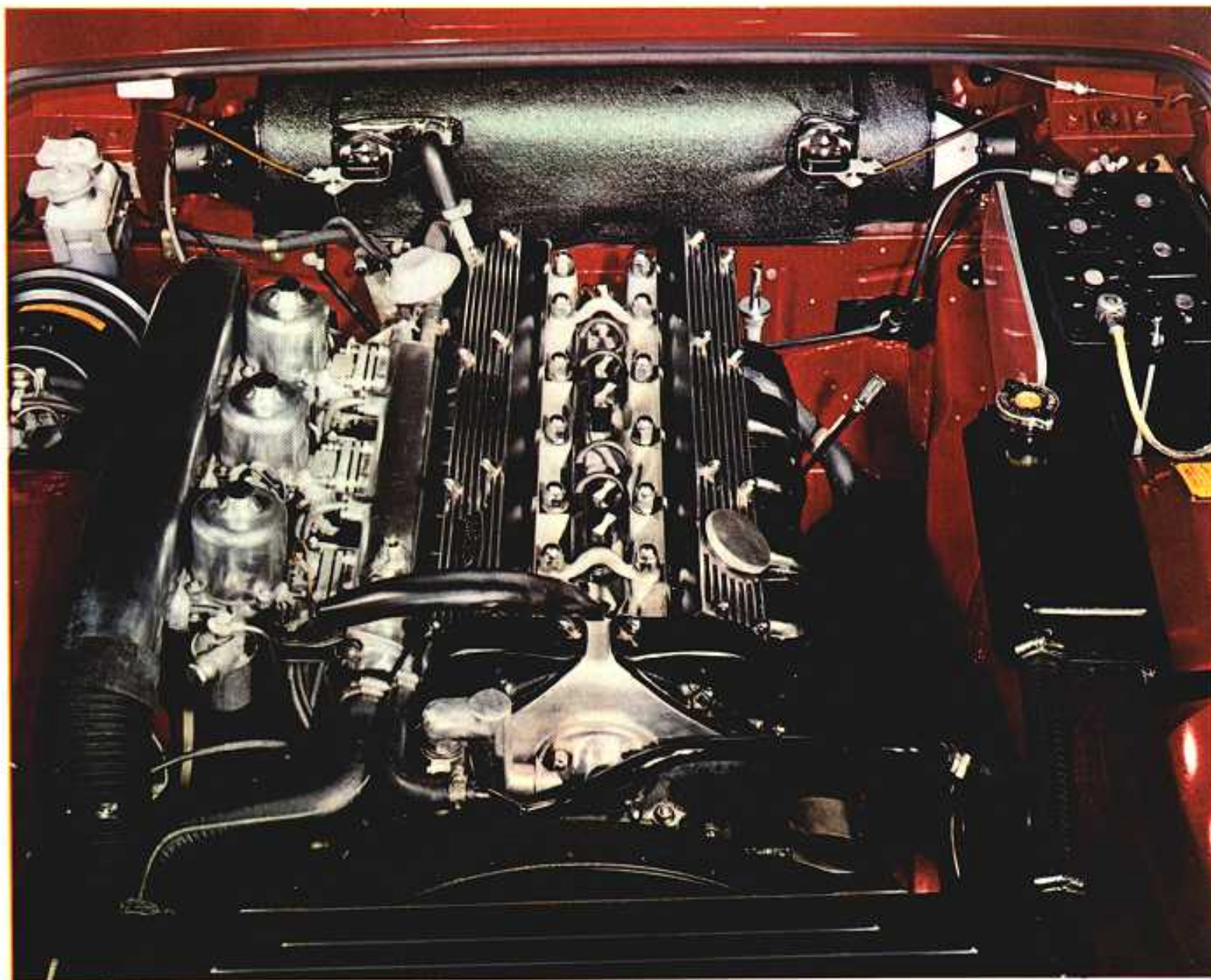

## the height of perfection . .

The superbly engineered Jaguar 'XK' engine, proven on the race and rally circuits of the world, is produced in 4.2 litre, triple carburettor form for the Jaguar 420 G. It develops 255 b.h.p. and 283 lb/ft. torque. Utterly devoid of temperament the 'XK' engine delivers its very high power and torque smoothly and silently over the full extent of its wide speed range. It is renowned for its consistency of performance and for its ability to run extraordinary mileages with complete reliability.

"Probably the most famous engine ever produced by the British Motor Industry"

(Motor)





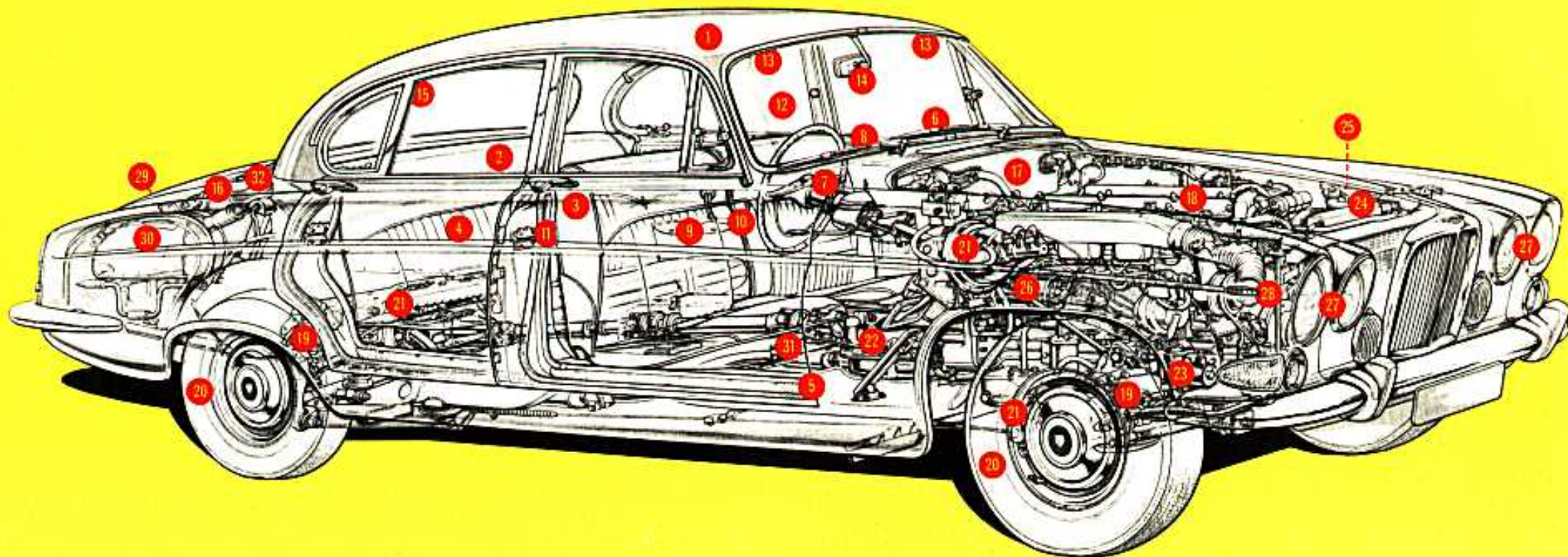

The comprehensive specification of the Jaguar 420 G combines power, performance, luxury, prestige and advanced engineering.

- |                                                                                                                                                                                                                                                                                                                                                                                                                                                                                                                                                                                                                                                                                                                                                                                                                                                                                                                                                                                                                                                                                            |                                                                                                                                                                                                                                                                                                                                                                                                                                                                                                                                                                                                                                                                                                                                                                                                                                                                                                                                                                                                                                                                                                                                                                                 |                                                                                                                                                                                                                                                                                                                                                                                                                                                                                                                                                                                                                                                                                                                                                                                                          |
|--------------------------------------------------------------------------------------------------------------------------------------------------------------------------------------------------------------------------------------------------------------------------------------------------------------------------------------------------------------------------------------------------------------------------------------------------------------------------------------------------------------------------------------------------------------------------------------------------------------------------------------------------------------------------------------------------------------------------------------------------------------------------------------------------------------------------------------------------------------------------------------------------------------------------------------------------------------------------------------------------------------------------------------------------------------------------------------------|---------------------------------------------------------------------------------------------------------------------------------------------------------------------------------------------------------------------------------------------------------------------------------------------------------------------------------------------------------------------------------------------------------------------------------------------------------------------------------------------------------------------------------------------------------------------------------------------------------------------------------------------------------------------------------------------------------------------------------------------------------------------------------------------------------------------------------------------------------------------------------------------------------------------------------------------------------------------------------------------------------------------------------------------------------------------------------------------------------------------------------------------------------------------------------|----------------------------------------------------------------------------------------------------------------------------------------------------------------------------------------------------------------------------------------------------------------------------------------------------------------------------------------------------------------------------------------------------------------------------------------------------------------------------------------------------------------------------------------------------------------------------------------------------------------------------------------------------------------------------------------------------------------------------------------------------------------------------------------------------------|
| <p>1 All steel 'monocoque' body, comprehensively sound-and-rust proofed and finished to the highest standards.</p> <p>2 Expansive accommodation for five people.</p> <p>3 Reclining front seats with combined height and reach adjustment.</p> <p>4 Luxurious leather hide ventilated upholstery for front and rear seats.</p> <p>5 Deep pile carpets over thick felt underlay.</p> <p>6 Safety padded lower screen rail and front parcels shelf.</p> <p>7 Telescopically adjustable steering column.</p> <p>8 Comprehensive instrumentation including impulse-driven revolution counter, transistorised electric clock, combined handbrake and brake fluid level warning light.</p> <p>9 Door panel armrests front and rear.</p> <p>10 Folding central armrests front and rear.</p> <p>11 Fold-away picnic tables with vanity mirrors incorporated in rear of front seats and flush fitting ashtrays front and rear.</p> <p>12 Zone toughened windscreen.</p> <p>13 Padded sun visors.</p> <p>14 Wide view rear mirror with dimmer control.</p> <p>15 Rear compartment assist straps.</p> | <p>16 27 cubic feet luggage compartment, fully lined and with interior lamp operated by boot lid. Spare wheel in fitted cover.</p> <p>17 High efficiency fresh air heating and demisting system with (A) Independent heater controls for each side of front compartment; (B) Variable direction air flow to front compartment; (C) Separate ducting for air supply to rear compartment; (D) Twin 2-speed booster fans; (E) Servo-operated air intake and water valves.</p> <p>18 Three carburetter, 4.2 litre, six cylinder, twin overhead camshaft 'XK' engine, developing 265 b.h.p. and 285 lb./ft torque to give outstanding acceleration and flexibility throughout the speed range.</p> <p>19 Fully independent suspension on all four wheels.</p> <p>20 Wide section SP+1 tyres.</p> <p>21 Servo-assisted self adjusting disc brakes on all four wheels for maximum all-round efficiency with separate hydraulic circuits to front and rear brakes. Self adjusting handbrake operating on rear wheels.</p> <p>22 Choice of transmission: All synchromesh four-speed manual, with or without overdrive, or Borg Warner model 8 automatic with D1/D2 dual drive range.</p> | <p>23 'Varamatic' varying ratio power-assisted steering.</p> <p>24 High efficiency cooling system with viscous coupling fan to reduce power absorption.</p> <p>25 Alternator generator for high current output, particularly at low engine speeds (located on nearside of engine).</p> <p>26 Pre-engaged starter for cold weather starting efficiency.</p> <p>27 Four headlamp lighting system with flashing control.</p> <p>28 Additional repeater-type direction indicators mounted on each side of the car.</p> <p>29 Twin reversing lamps.</p> <p>30 Twin fuel tanks (one in each rear wing) 20 gallons total capacity, with change-over switch on instrument panel.</p> <p>31 Twin exhaust system with aluminised multi-silencers.</p> <p>32 Fuel filler with lockable lid to each petrol tank.</p> |
|--------------------------------------------------------------------------------------------------------------------------------------------------------------------------------------------------------------------------------------------------------------------------------------------------------------------------------------------------------------------------------------------------------------------------------------------------------------------------------------------------------------------------------------------------------------------------------------------------------------------------------------------------------------------------------------------------------------------------------------------------------------------------------------------------------------------------------------------------------------------------------------------------------------------------------------------------------------------------------------------------------------------------------------------------------------------------------------------|---------------------------------------------------------------------------------------------------------------------------------------------------------------------------------------------------------------------------------------------------------------------------------------------------------------------------------------------------------------------------------------------------------------------------------------------------------------------------------------------------------------------------------------------------------------------------------------------------------------------------------------------------------------------------------------------------------------------------------------------------------------------------------------------------------------------------------------------------------------------------------------------------------------------------------------------------------------------------------------------------------------------------------------------------------------------------------------------------------------------------------------------------------------------------------|----------------------------------------------------------------------------------------------------------------------------------------------------------------------------------------------------------------------------------------------------------------------------------------------------------------------------------------------------------------------------------------------------------------------------------------------------------------------------------------------------------------------------------------------------------------------------------------------------------------------------------------------------------------------------------------------------------------------------------------------------------------------------------------------------------|

**OPTIONAL EXTRA FEATURES:** Electrically heated rear window. Foglamps. Full air conditioning. Radio with remote control aerial. Laminated windscreen. Anti-theft steering lock. Electric lift windows. Rear seat belts.

## Principal Dimensions · 420 G

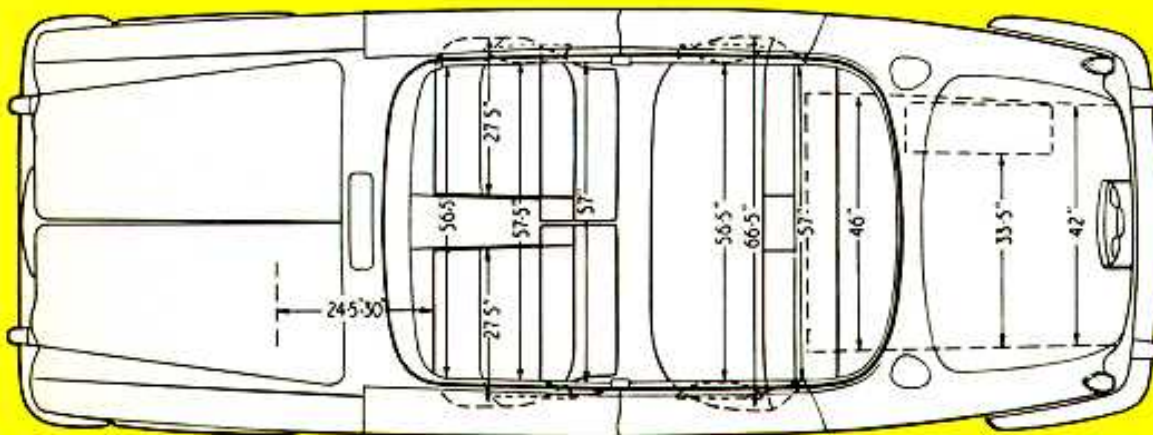
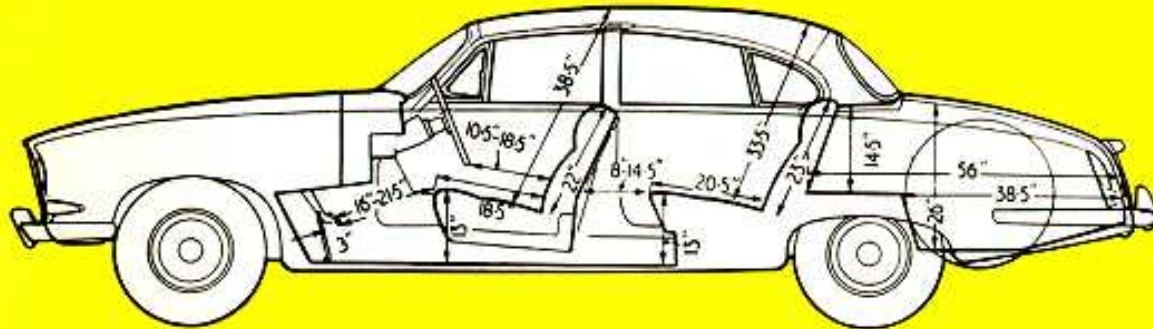

JAGUAR CARS LIMITED · COVENTRY · ENGLAND

*The issue of this catalogue does not constitute an offer. The specification described in this brochure varies for different countries, and Jaguar Cars Ltd. reserve the right to amend specifications at any time without notice.*

## Colour Schemes

The colour schemes listed below are standard and any deviation involving special treatment of coachwork and/or upholstery will entail extra charge for which a quotation will be given at time of ordering.

Coachwork	Interior Colour Alternatives
CREAM	RED, LIGHT BLUE, DARK BLUE
WARWICK GREY	RED, DARK BLUE, CINNAMON
ASCOT FAWN	RED, BEIGE, CINNAMON
SABLE	BEIGE, GREY, CINNAMON
REGENCY RED	BEIGE, GREY
WILLOW GREEN	SUEDE GREEN, BEIGE, GREY, CINNAMON
BRITISH RACING GREEN	SUEDE GREEN, BEIGE, CINNAMON
LIGHT BLUE	DARK BLUE, GREY, LIGHT BLUE
DARK BLUE	RED, LIGHT BLUE, GREY
BLACK	RED, GREY, CINNAMON

The 420G Saloon is also available with the following Duo-Tone paint finishes

BLACK over ASCOT FAWN	RED, GREY, CINNAMON
BLACK over WARWICK GREY	RED, GREY, CINNAMON
DARK BLUE over LIGHT BLUE	RED, LIGHT BLUE, GREY
BRITISH RACING GREEN over WILLOW GREEN	SUEDE GREEN, BEIGE, CINNAMON

# THE JAGUAR 420 G SPECIFICATION

**ENGINE.** 6 cylinder, twin overhead camshaft, 4.2 litre 'XK' Jaguar engine, 92.07 mm. bore  $\times$  106 mm. stroke (5.625" by 4.1752"). Cubic capacity 4255 c.c. (258.45 cu. ins.). Compression ratio 8:1. Power output, 255 b.h.p. at 5,400 r.p.m. Torque 283 lb/ft at 4,000 r.p.m. Three S.U. carburettors, type HD.8, with automatic starting control. Forced lubrication incorporating a full flow filter. Chrome iron cylinder block fitted with dry type cylinder liners. Special 'straight port' cylinder head of high tensile aluminium alloy featuring hemispherical combustion chambers and twin overhead camshafts operating large valves of 70° included angle. Aluminium alloy pistons. Steel connecting rods fitted with lead indium big-end bearings. 2 $\frac{1}{4}$  ins. diameter counterweighted crankshaft carried on seven large lead indium bearings. Pressurised cooling system with thermostatic control and viscous coupling fan.

**TRANSMISSION.** (Manually operated gearbox). Four-speed single helical all synchromesh gearbox. Gear change lever on floor between front seats. Gear ratios: 1st, 10.76; 2nd, 6.98; 3rd, 4.70; Top, 5.54; Reverse, 12.55. Borg and Beck diaphragm spring clutch with hydraulic operation. Divided propeller shaft.

**TRANSMISSION.** (Overdrive model). As above, with addition of a Laycock de Normanville overdrive controlled by a lever mounted on the steering column. Gear ratios: 1st, 11.46; 2nd, 7.44; 3rd, 5.00; Top, 5.77; Overdrive, 2.95; Reverse, 13.16. Divided propeller shaft.

**TRANSMISSION.** (Automatic Transmission model). Borg Warner Model 8 automatic transmission with dual drive range D1/D2. Gear ratios: Low, 8.5/17.0; Intermediate, 5.16/10.32; Top, 5.54/7.08; Reverse, 7.08/14.16. Gear selector lever on steering column. Divided propeller shaft.

**SUSPENSION—FRONT.** Independent front suspension incorporating double wishbones and coil springs with telescopic shock absorbers. Anti-roll bar located between lower wishbones.

**SUSPENSION—REAR.** Fully independent rear suspension incorporating on each side, a lower transverse tubular link pivoted at the wheel carrier and subframe adjacent to the differential case and, above this, a half shaft universally jointed at each end. These serve to locate the wheel in a transverse plane. Longitudinal location is provided by the rubber mountings locating the sub-assembly in the body structure and by a radius arm between the lower link and a mounting point on the body structure. Twin coil springs, each enclosing a telescopic hydraulic damper, provide the suspension medium. The whole assembly together with the differential unit is carried in an easily detachable sub-frame which is located in the body structure by rubber mountings.

**BRAKES.** Disc brakes, featuring quick change pads are fitted to all four wheels. Front brakes fitted on wheel hubs, rear brakes fitted inboard of half shafts adjacent to differential unit. System is divided into two entirely independent hydraulic circuits to front and rear brakes. Operation is by suspended vacuum tandem type servo operated by a master cylinder and reaction valve. Handbrake with automatic adjustment operates on rear wheels only. Combined handbrake "on" and brake fluid level warning light.

**STEERING.** 'Variable' varying ratio power-assisted steering. Ratio 21.5:1 in straight ahead position varying to 15:1 at full lock. 2.75 turns lock to lock. Power supplied by vane pump, incorporating its own fluid reservoir, and driven from front of crankshaft by separate belt. 17 in. diameter steering wheel adjustable for reach. Turning circle 57 ft.

**WHEELS AND TYRES.** Pressed steel bolt-on disc wheels fitted with Dunlop 205 mm.  $\times$  14 in. SP.41 tyres and tubes.

**FUEL SUPPLY.** Twin petrol tanks—one in each rear wing—with total capacity of 20 gallons (91 litres). Filter incorporated in fuel line to carburettors. Twin S.U. electric pumps controlled by tank changeover switch mounted on fascia panel. Fuel gauge records contents of tank in use. The separate fillers to each tank are concealed beneath lockable covers.

**ELECTRICAL EQUIPMENT AND INSTRUMENTS.** Lucas alternator, 12 volt battery with negative earth system. 60 amp./hour at 10 hour rate with current voltage control. Sidelamps. Four headlamps controlled by foot operated dip-switch. Separate lever for actuating headlamp flashing. Separate stop/tail, direction and reflector units mounted in a single assembly. Twin reversing lamps. Self-cancelling flashing direction indicators with warning lights. Instru-

ments and labelled switches illuminated by internal flood lighting controlled by a two-position dimmer switch. Concealed map-reading lamp beneath screen rail in front compartment. Courtesy lights above the centre door pillar, and above the rear window, operated either manually by switch on the instrument panel or automatically by any of the four doors. Luggage boot illumination controlled by automatic switch. Cigar lighter with luminous socket. Twin-blended windtone horns. Twin blade, two-speed, self-parking windscreen wipers. Electrically operated windscreen washers. Pre-engaged type starter motor. Vacuum and centrifugal automatic ignition advance. Oil coil ignition, 5 ins. diameter speedometer incorporating total trip and distance recorder. 5 ins. diameter impulse driven revolution counter. Ammeter, electrically operated oil pressure gauge, water temperature gauge, fuel gauge, combined handbrake and brake fluid level warning light, separate transistorised time clock.

**BODY.** All steel four-door five seater saloon of monocoque construction providing maximum rigidity with minimum weight. Large semi-wraparound windscreen with slim pillars and semi-wraparound rear window for maximum visibility front and rear. The semi-wraparound windscreen does not interfere with ease of entry and exit. Wide view rear mirror with dimmer control. Chromium plated window frames on all four doors, which are hinged at their forward end and fitted with check straps. Initial opening of doors assisted by use of torsion bars to front doors and springs to rear doors. Special door handles incorporating push buttons designed to prevent freezing up in extremely cold conditions. Seats upholstered in finest quality Vauinol ventilated leather hide over deep Dunlopillo foam cushions. Reclining type front seats, fitted with central folding armrests. Combined adjustment for height and reach. Seats incorporate flush-fitting tables and ashtrays in the backs of the squabs. Each table when opened reveals a large rectangular mirror. Padded safety screen rail incorporates centrally mounted transistorised clock. Polished figured walnut instrument panel features revolution counter and speedometer positioned directly in front of driver and separate instruments for oil pressure, water temperature, fuel gauge and ammeter. Instrument panel contains on the passenger's side a glove compartment with interior light and lockable lid. A large parcel shelf runs the full width of the car and carries in its padded forward edge the heater controls. Map pocket on passenger's side below parcel shelf. Separate housing beneath the parcel shelf contains a radio and speaker (optional extra), and a large ashtray. When no radio is fitted, the speaker grille is retained and the radio control panel aperture is blanked off with an escutcheon. Two-spoke steering wheel and semi-circular horn ring. Front and rear doors incorporate armrests. Central folding armrests in rear compartment. Sun visors. Deep pile carpet over thick felt underlay. Heavy duty wraparound bumpers with overrides. Counterbalanced, forward opening bonnet. Seat belt anchorages are incorporated for both front and rear seats.

**HEATING AND DEMISTING.** Fresh air heating system capable of delivering a large volume of air at high or ambient temperature. Individual controls for each side of car regulate temperature and direction of air. Separate ducting to rear compartment. Air intake and temperature controls are servo operated. Twin 2-speed centrifugal blowers controlled by switch on instrument panel.

**LUGGAGE ACCOMMODATION.** Ample luggage accommodation is provided in an extremely large rear boot of 27 cubic feet capacity. Illumination is provided by an automatically controlled interior light operated by opening the boot lid, which is counterbalanced by torsion bars for ease of operation. Boot and spare wheel fully trimmed to protect luggage.

**SPARE WHEEL AND TOOLS.** The spare wheel is carried vertically in the luggage compartment and is readily accessible. A comprehensive set of tools is also supplied in a special container and this together with wheel changing equipment is fitted behind the spare wheel.

**JACKING.** Exterior jacking posts on each side enable the car to be lifted with the minimum of effort by means of the jack provided.

**PRINCIPAL DIMENSIONS.** Wheelbase 10 ft., track front 4 ft. 10 ins., track rear 4 ft. 10 ins., overall length 16 ft. 10 ins., overall width 6 ft. 4 ins., overall height 4 ft. 6 $\frac{1}{2}$  ins., ground clearance 6 $\frac{1}{2}$  ins., dry weight: 5947 lbs.