

**Your car Sir!**

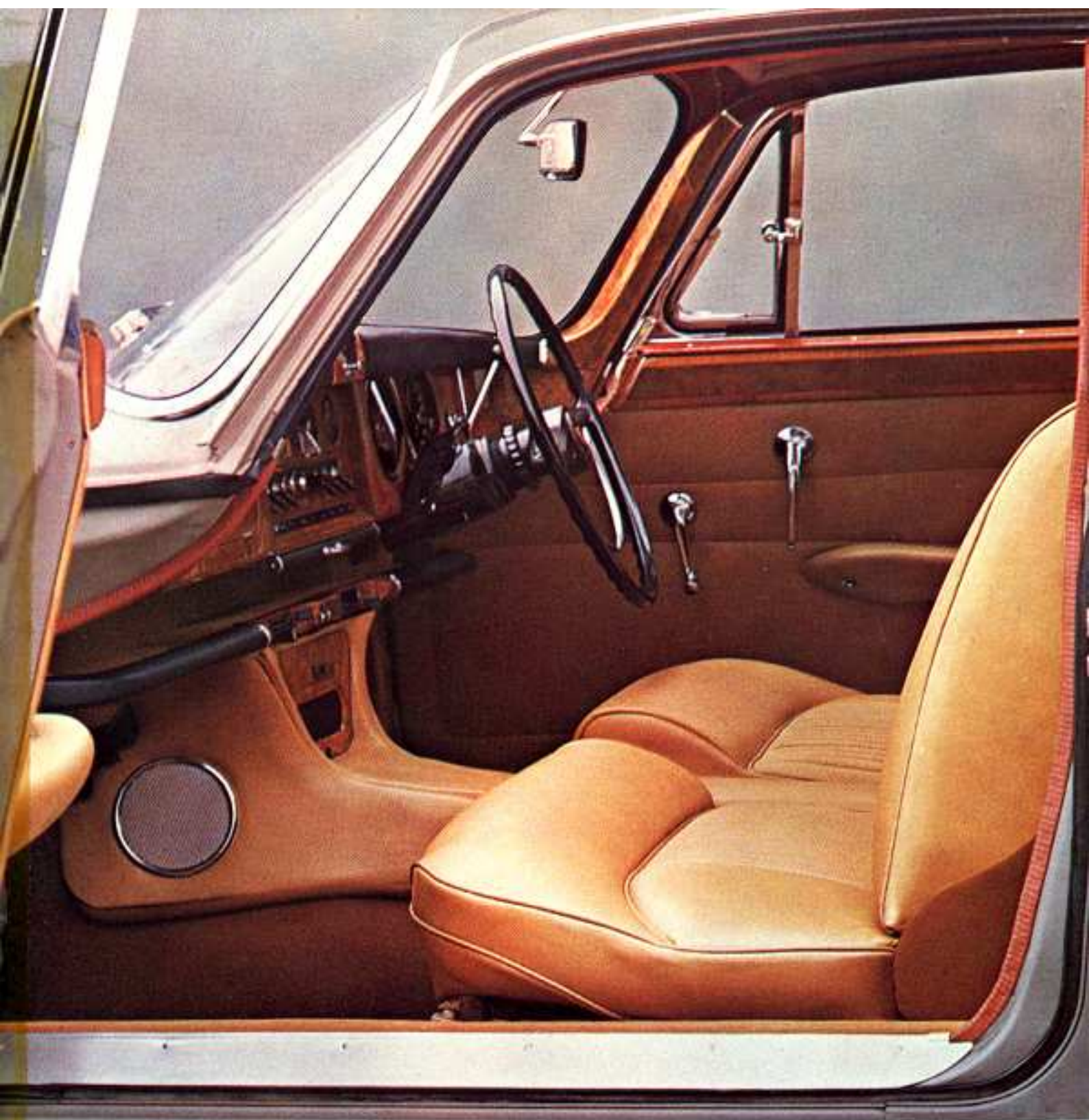



**The Jaguar 420G—  
the car built around  
the company director.**

Sink into your elegant seat. Stretch out your legs. Give the word to your chauffeur. And glide noiselessly away.

Your first sensation is one of space. More than enough room for five large-size adults. And more than enough room for their briefcases, umbrellas, hats and other impedimenta.





Then examine the comfort of your surroundings. Armrests, picnic-tables, carpets, ventilation. All designed to put you at your ease. And if privacy is as important as comfort there's a limousine version with a sliding glass partition. We know you company directors like to keep your secrets.







## Your turn behind the wheel.

Don't let your chauffeur have all the fun. Get into the driving seat. A word of warning. Make sure to look at the rev counter to check the motor's running.

Under the bonnet you've got the famous race-proven Jaguar XK engine. 4.2 litre, 6 cylinder, 255 b.h.p. Renowned for its power and flexibility.

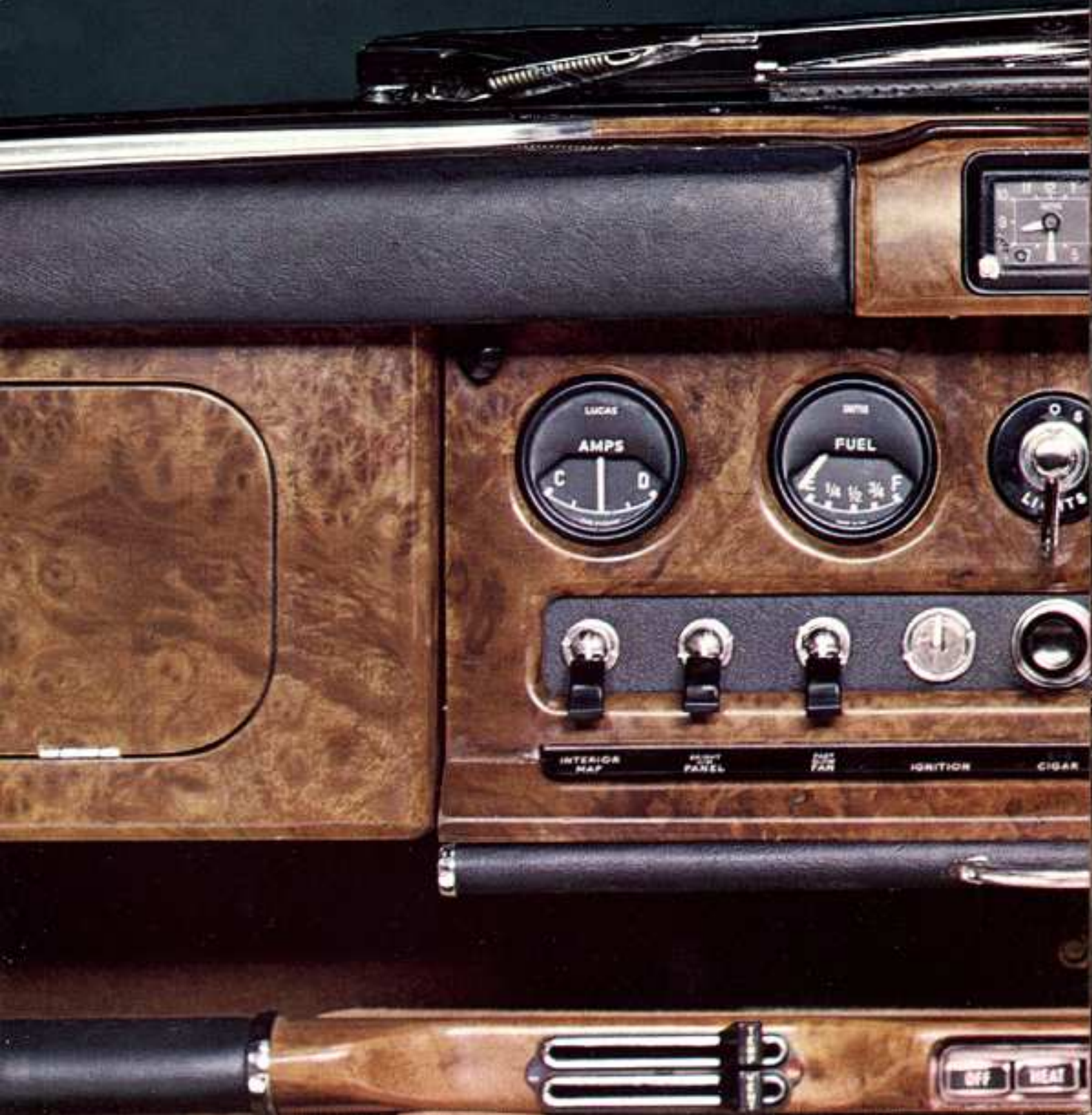



# Specification

**ENGINE.** Six cylinder 4.2 litre 'XK' engine with twin overhead camshafts and three carburettors. 92.07 mm. bore X 106 mm. stroke. Capacity 4,235 c.c., 255 b.h.p. at 5,400 r.p.m. Compression ratio 8 to 1. Cooling system incorporates cross-flow tube and fin radiator block, fluid drive speed-control fan and improved design water pump.

**TRANSMISSION.** (Manual) Four-speed all-synchromesh gearbox; gear change lever on floor between front seats. (Overdrive) As above, with addition of a Laycock de Normanville overdrive controlled by lever on steering column. (Automatic) Borg Warner automatic transmission with dual drive range D1/D2. Selector lever on steering column.

**SUSPENSION.** (Front) Independent suspension – double wishbones, coil springs with telescopic shock absorbers. (Rear) Fully independent suspension incorporating, on each side, a lower transverse link pivoted at wheel carrier and subframe adjacent to differential case and, above this, a half-shaft universally jointed at each end. Twin coil springs each enclose a telescopic hydraulic damper.

**BRAKES.** Servo-assisted disc brakes all round. Independent hydraulic circuits to front and rear. Self adjusting handbrake.

**STEERING.** "Varamatic" variable ratio power steering. 2.75 turns lock to lock.

**WHEELS & TYRES.** Pressed steel bolt-on disc wheels. Dunlop 205 mm. X 14 in. SP41 tyres and tubes.

**FUEL SUPPLY.** Twin tanks, total capacity 20 gallons. Twin electric pumps. Separate concealed fillers. Change-over switch on fascia panel.

**ELECTRICAL EQUIPMENT & INSTRUMENTS.** Alternator generator. 12-volt battery with negative earth system. Extensive equipment includes – Four headlamp system, headlamp flashing unit, twin reversing lamps, map reading lamp, continental side wipers, cigar lighter, twin-blade two-speed windscreen wipers, windscreen washers, automatic ignition advance, transistorised clock, all fitted as standard. Comprehensive instrumentation to Jaguar normal high standards.

**BODY.** All steel four-door five-seater saloon. Luxurious upholstery in ventilated leather hide over deep Dunlopillo cushions. Central folding armrests front and rear. Reclining front seats with flush fitting picnic trays in backs of squabs. Deep pile carpets over thick felt underlay. Padded safety screen rail. 27 cubic feet capacity luggage boot.

**HEATING & DEMISTING.** High output system. Regulation for temperature, volume and direction of air for each side of saloon. Separate ducting to rear compartment.

**SPARE WHEEL & TOOLS.** Spare wheel housed in luggage boot and fully trimmed to protect luggage. Comprehensive set of tools in special container.





**Five people's luggage. Most of the files in your office. Or seven dozen of claret. Easily swallowed by 27 cubic feet of boot.**

**An interior light is operated automatically by opening the boot lid. And the whole boot is fully trimmed to protect luggage.**















# Principal Dimensions · 420 G

Wheelbase 10ft., track front 4ft. 10ins., track rear 4ft. 10ins., overall length 16ft. 10ins., overall width 6ft. 4ins., overall height 4ft. 6½ins., turning circle 37ft.

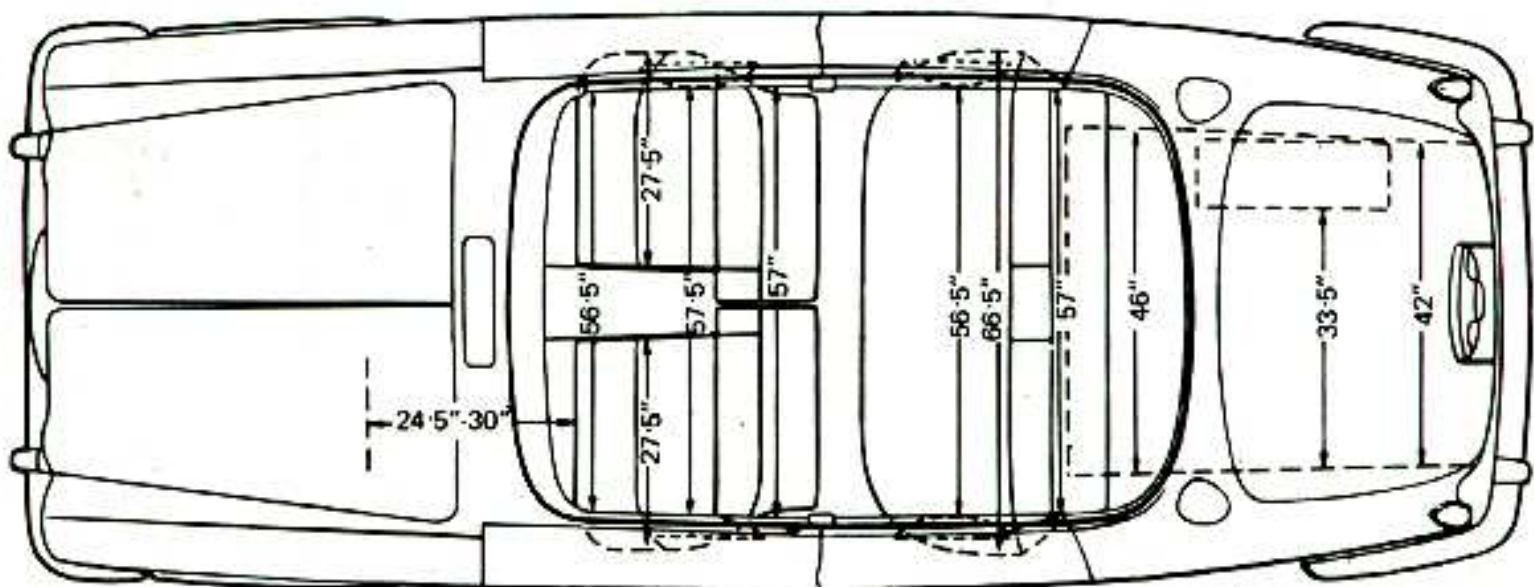
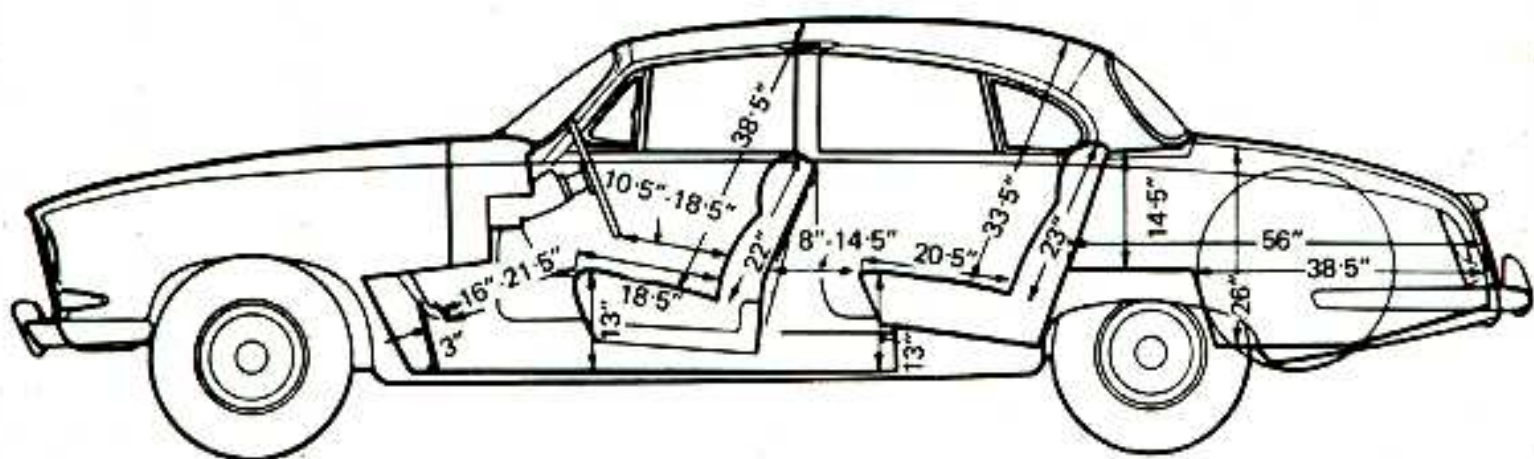

## JAGUAR CARS LIMITED · COVENTRY · ENGLAND

The issue of this catalogue does not constitute an offer. The specification described in this brochure varies for different countries, and Jaguar Cars Ltd. reserve the right to amend specifications at any time without notice. Due to tolerances all measurements and weights in this catalogue are approximate. The colours printed in this catalogue may differ from actual paint colours. For details of colour range available please consult your local Distributor or Dealer.



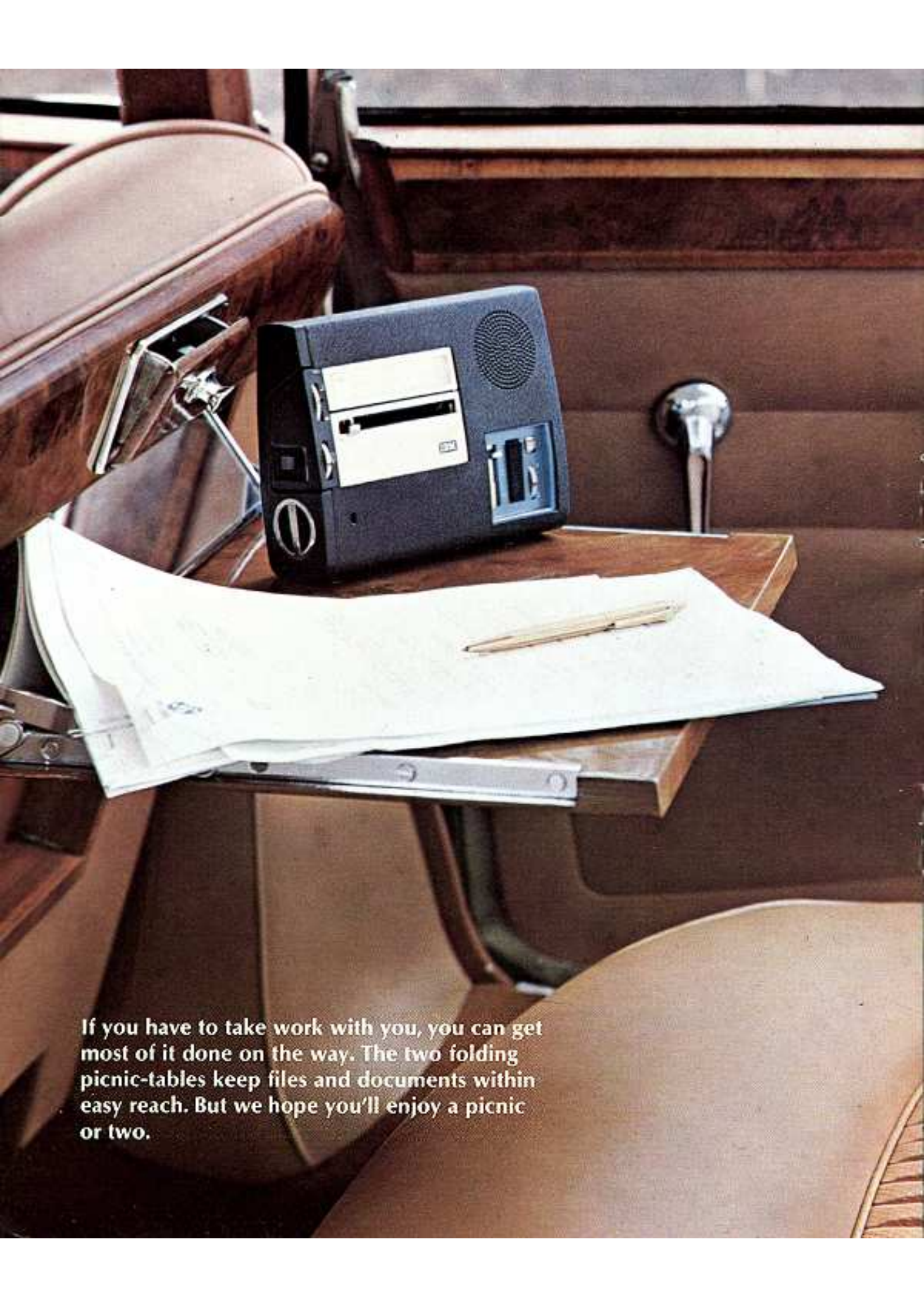

If you have to take work with you, you can get most of it done on the way. The two folding picnic-tables keep files and documents within easy reach. But we hope you'll enjoy a picnic or two.





**We could go on for ever about the 420G. About the luxury. About the smoothness of the ride. About extras like intercoms and air-conditioning. But the only real way to appreciate this car is to drive it yourself. And that's what we'd like you to do.**



Whether you prefer manual or automatic drive the car responds instantly. In traffic, on country lanes, on the motorway. Treat yourself to a test drive and see for yourself.

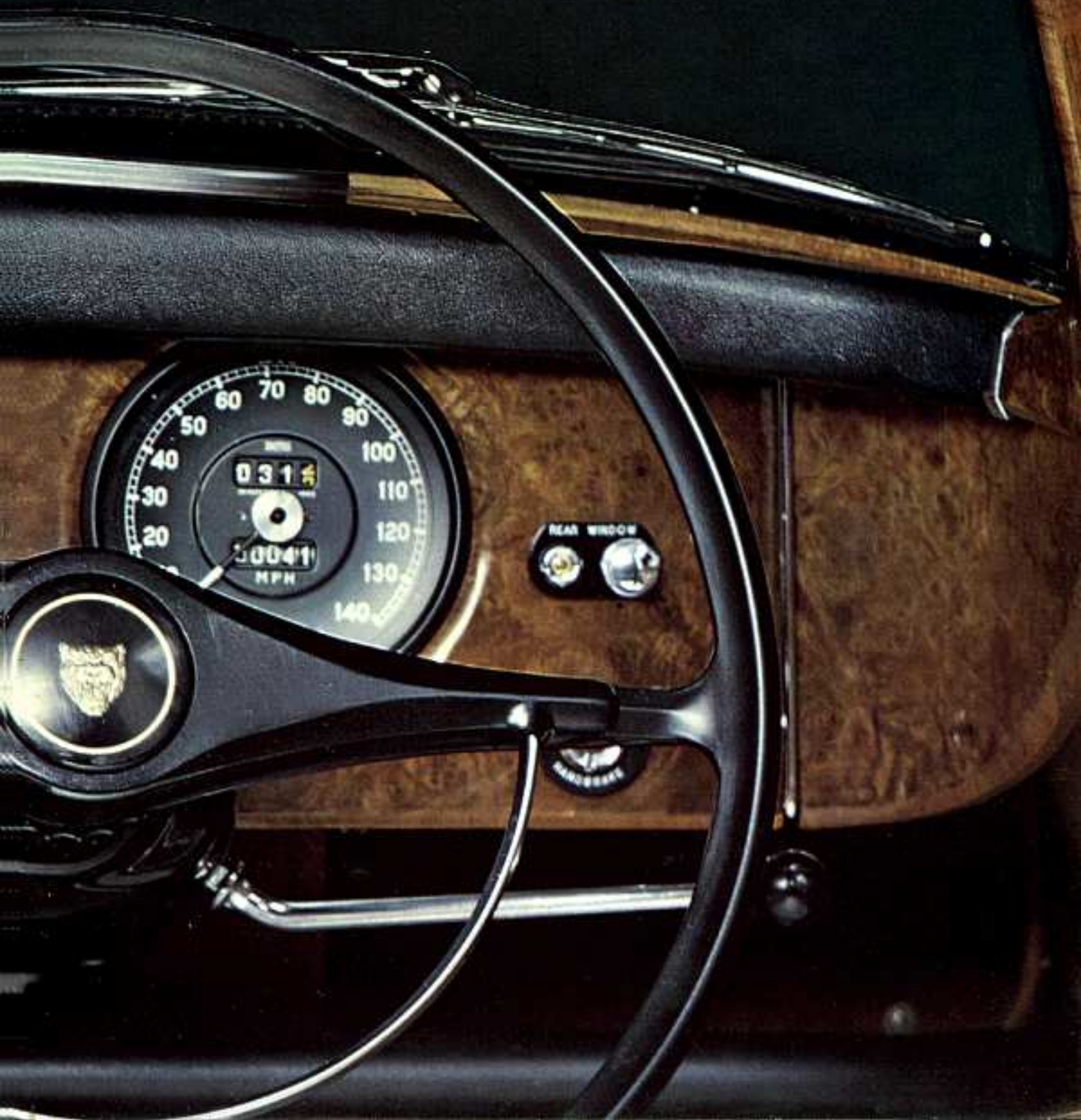



The performance of the 420G is acknowledged by the motoring press of the world. Independent suspension all round keeps you glued to the road. And disc brakes ensure balanced stopping power.

