THE 1982 JAGUAR XJ-S





**Never has a more
exciting car been
offered with so
much, to so few.**

The Jaguar S-type is first and foremost a driver's car. For here, under one dynamic, wind-cheating shape is a blending of power, response and handling with a degree of luxury and refinement unequalled in any four passenger touring machine. The XJ-S is unrivalled in the smooth thrust of power generated by its advanced V-12 engine, the only V-12 available in America.

For 1982, the S-type engine has been refined with the addition of advanced combustion technology available on no other car: the high compression May head. The innovative design of the compression chamber swirls and compacts the fuel/air mixture at the point of ignition allowing a rapid yet complete burn. This enables the engine to run on a leaner mixture and a higher compression using regular unleaded fuel. The result: increased performance and response.



To match its performance, the S-type offers a level of handling and stability comparable to that of a racing machine. This is only natural for a car whose racing version competes successfully in grueling Trans-Am races. The steering is rack and pinion, power assisted and extraordinarily precise. The feel for the road is sure and positive with fully independent

suspension on all four wheels. And the S-type stops with the authority of four-wheel power disc brakes.

Probably no maximum performance car has ever offered so much luxury. The dashboard and door panels are inset with veneers of rare burl elm. The entire seating compartment is covered in supple leather. The new four-speaker stereo-

phonic AM/FM radio has a scan tuner and cassette with Dolby™ sound. The XJ-S is equipped with cruise control, power windows and door locks and much more.

Few people will be privileged to own this dynamic new Jaguar. Yet, before you decide on any personal luxury car, you owe it to yourself to seek out the S-type and drive it. For the name of the Jaguar dealer nearest you, call these numbers toll-free: (800) 447-4700 or, in Illinois, (800) 322-4400.

☐ Jaguar, Leonia, New Jersey 07605.



**FOR A MORE EXCITING CAR,
AN EXTENDED WARRANTY.**

Because of our confidence in the 1982 XJ-S, Jaguar offers it with the longest warranty in Jaguar history. For two years or 36,000 miles, whichever comes first, Jaguar will replace or repair any part of the S-type which is defective. The tires are covered by their own manufacturer's warranty. See your Jaguar dealer for complete details of this limited warranty.

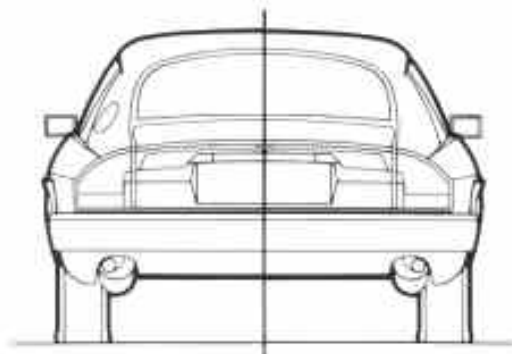
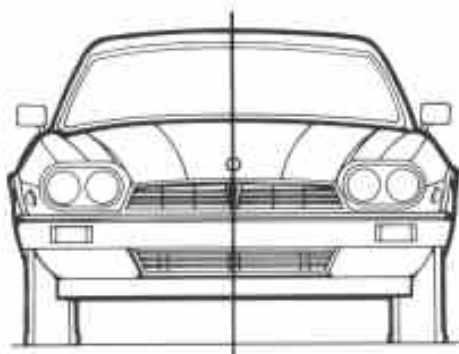
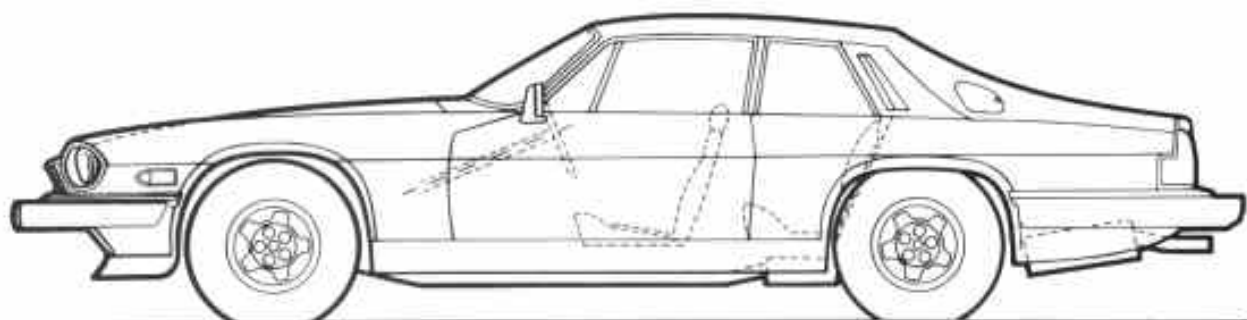

JAGUAR XJ-S SPECIFICATIONS

ENGINE:

12-cylinder water-cooled aluminum-alloy 60-degree V with overhead camshafts (1 per bank) • May high compression cylinder head • 3-plane 7-bearing crankshaft • Exhaust and evaporative emission control • Catalytic converters • Compression ratio 11.5:1 • Bore 3.54 in • Stroke 2.76 in • Stroke/bore ratio 0.78:1 • Displacement 326 cu in. (5345 cc) • Ignition: Constant Energy Electronic system consisting of electronic distributor with rotor arm, amplifier unit, and twin high performance coils • Fuel Injection: Lucas digitally controlled electronic with separate automatic cold start injector • Fuel Pump: Electric • Fuel Tank Capacity: 24 U.S. gallons (unleaded) • Sump Capacity: 11 U.S. quarts

DRIVETRAIN:

Transmission: GM 400-80 three-speed fully automatic with overriding manual control-torque converter • Final Drive: Independent Hypoid type with limited-slip differential • Rear Axle Ratio: 2.88:1 • Gear Ratios: Reverse 2.0:1; First 2.5:1; Second 1.5:1; Drive 1.0:1

STEERING:

Rack and pinion power-assisted • Leather bound steering wheel • Adjustable steering column • Turns-lock to lock 2.7 • Turning circle 39.4 ft

SUSPENSION:

Front: Independent "anti-dive" geometry with semi-trailing wishbones incorporating coil springs, shock absorbers and anti-sway bar • Rear: Independent with drive shafts forming upper links, radius arms, paired shock absorbers with coil springs and anti-sway bar

BRAKES:

Servo-assisted 4-wheel disc brakes, dual circuits front to rear with pressure differential warning actuator • Front: 11.16 in. diameter ventilated discs • Rear: 10.38 in. diameter disc mounted inboard

ROAD WHEELS:

Five spoke cast aluminum-alloy wheels, 15 in. diameter, fitted with Pirelli P5 215/70 VR 15 steel belted, radial-ply tubeless tires

ELECTRICAL:

Negative ground 12-volt system • Low maintenance battery • Battery Rating: 68 amps at 20 hour rate • Alternator: 60 amps

INSTRUMENTS AND CONTROLS:

Speedometer with trip odometer • Electric tachometer • Gauges for fuel level, water temperature, oil pressure and battery condition • Dual warning light system for vehicle status and vital functions including main beam, hazard warning, ignition, handbrake, brake hydraulic failure, oil pressure, direction indicators, low coolant, heated rear window, seat belt not fastened, bulb failure and oxygen sensor service • Cruise control (on/off/resume); power window switches on console • Multi-purpose lever on left side of steering column controls low beam/high beam/flasher and directionals, and cruise control "set"; right side lever controls electric windshield wiper and two speed wipers with single-wipe and intermittent capabilities • Door-operated courtesy lights with delayed "off" • Map reading lights • Luggage compartment light • Heated rear window • Central door locking by key or interior lock of either door • Twin electric remote control exterior mirrors operated from driver's side • Automatic door open warning lights incorporating puddle lights

BODY:

All steel monocoque, 2-door, 2+2 • Forward hinged hood • Tinted glass

INTERIOR:

Fully reclining leather-covered front seats adjustable for reach (with head restraints); leather covered rear seat • Leather covered door panels, bins, console and armrests • Burl elm

facia, control panel and inserts to door waist rail • Factory-installed air conditioning/heating unit with automatic temperature control; automatic fan with overriding manual control • Sound system: Cassette AM/FM stereo with electronic scan tuning, 4-way speaker balance, Dolby® and metal tape capability • Inertia-reel seat belts • Power windows • Console and lockable glove box • Electric dock • Cigarette lighter • Deep pile carpet • Carpeted trunk with spare tire cover

INTERIOR DIMENSIONS:

Front Seat Headroom: 37 in. • Rear Seat Headroom: 34 in. • Front Seat Legroom (maximum): 43.5 in. • Rear Seat Legroom (minimum): 25 in. • Front Seat Shoulder Width: 55.5 in. • Rear Seat Shoulder Width: 52 in. • Trunk Capacity (usable with spare tire-MVMA): 10.6 cu ft

MAIN DIMENSIONS:

Overall Length: 191.3 in. • Overall Height: 49.6 in. • Overall Width: 70.6 in. • Wheelbase: 102 in. • Track at Front: 58.6 in. • Track at Rear: 59.2 in. • Ground Clearance (minimum): 4.5 in. • Curb Weight: 3,980 lbs.

OPTIONAL EQUIPMENT:

None

JAGUAR CARS CONFORM TO U.S. FEDERAL MOTOR VEHICLE SAFETY AND AIR POLLUTION STANDARDS APPLICABLE AT THEIR DATE OF MANUFACTURE. SPECIFICATIONS AND COLORS SUBJECT TO CHANGE WITHOUT NOTICE.

☐ Jaguar, Leonia, New Jersey 07605.
In Canada: 8 Indell Lane, Bramalea,
Ont. L6T 4H3